

# Specifications for V609E

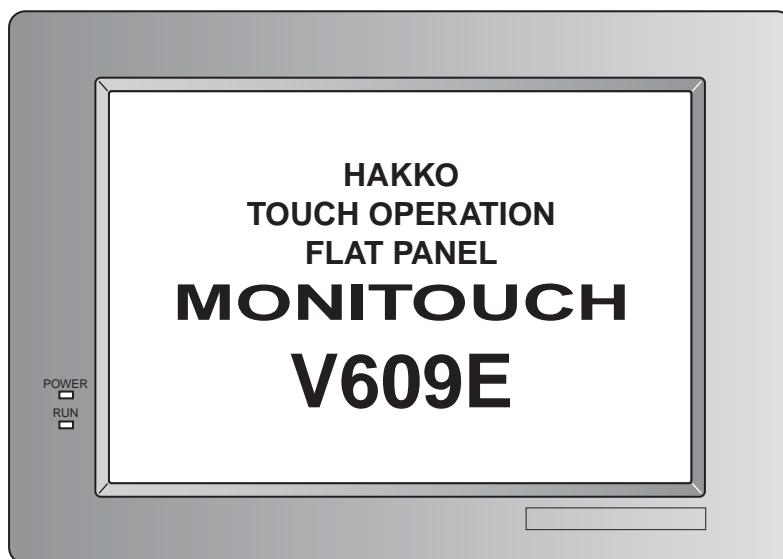



Record of Revision

<b>Printing Date</b>	<b>Reference No.</b>	<b>Revised Contents</b>
June, 2001	1040NE0	First Edition
December, 2003	1040NE1	Second Edition (A partial revision) <ul style="list-style-type: none"> <li>•Available PLCs for multi-drop, multi-link2 and multi-link modified</li> <li>•Specifications of SRAM &amp; Built-in clock added</li> <li>•GD-80E -&gt; V609E Conversion modified</li> </ul>



# Preface

---

Thank you for selecting the MONITOUCH V6 series.

For proper set-up, you are requested to read through this booklet to understand more about the product.

For more information about V6 series, refer to the following manuals.

Contents	Name of Manuals	Ref. No.
Shows wiring for each PLC, setting of "communication parameter" etc.	V6 Hardware Specifications	2006NEx
The V-SFT operating procedure is described.	Reference Manual (Operation)	1043NEx
The functions and instructions of V7/V6 series are described.	Reference Manual (Function)	1044NEx
Shows exercises in V-SFT edit.	V-SFT Tutorial	1022NEx
Shows how to connect and set Temperature Control Network	Temperature Control Network	1033NEx

For further details about the PLC, see the manual attached to each PLC.

Notes:

1. This booklet may not, in whole or in part, be printed or reproduced without the prior written consent of Hakko Electronics Co., Ltd.
2. Information in this booklet is subject to change without prior notice.



# Notes on safe usage of MONITOUCH

In this "Specifications for V609E", you will find various notes categorized under the following three levels with the signal words "Danger," "Warning," and "Caution."

These signal words are to warn the user of possible misuse of the unit. To comprehend the critical notes on the safe procedure, you must go through this manual before you install MONITOUCH and operate it correctly.



**DANGER**

## Danger

indicates an imminently hazardous situation which, if not avoided, will result in death or serious injury.



**WARNING**

## Warning

indicates a potentially hazardous situation which, if not avoided, could result in death or serious injury.



**CAUTION**

## Caution

indicates a potentially hazardous situation which, if not avoided, may result in minor or moderate injury and could cause property damage.

## Notes on System Design



### WARNING

Never use the input function of MONITOUCH such as the touch switch for an emergency switch because it could threaten a human life or break a part of the unit.

Please design the system of the unit in order to respond to a malfunction of the touch switch.



### CAUTION

Prevent the static electricity from being charged on the sheet metal where MONITOUCH is mounted in order to avoid malfunction caused by noise.

Never bundle input/output cables with high-voltage and large-current cables such as power supply cables. Keep input/output cables at least 200mm away from power supply cables in order to avoid malfunction caused by noise.

As for the use in the facilities related to nuclear energy or in the facilities of official importance, please consult with our distributor about it.

## Notes on Installation



### CAUTION

Operate MONITOUCH under the conditions indicated by the manual.

If you don't set the conditions indicated by the manual for the unit, it could cause fire, malfunction, physical damage or deterioration.

Maintain the following conditions in order to avoid fire or trouble.

Don't let the unit come in contact with corrosive gas, flammable gas, solvents, grinding fluids or cutting oil.

Never let the unit be exposed to high temperature, high humidity, and other outside weather conditions.

Don't allow the unit to be exposed to excessive dust, salt, and metallic particles.

Don't allow the unit to be shaken or hit by other objects.



Equipment must be correctly mounted so that the main terminal will not inadvertently be touched during an application.

## Notes on Cable Connection



**DANGER**

Turn off the power supply when you set up the system or connect the cables, otherwise you will get an electric shock or damage the unit.



**CAUTION**

Connect the cables correctly to the terminals of MONITOUCH in accordance with the specified voltage and wattage. Over-voltage, over-wattage and the incorrect cable connection could cause the unit to be damaged physically or functionally and also could result in fire.

Ground FG terminal which must be for the unit. The level of grounding resistance is less than 100Ω.

Prevent any conductive particles from entering into MONITOUCH. The conductive particles could cause fire, trouble, or malfunction of the unit.

## Notes on Maintenance and Operation



**DANGER**

Never touch the terminals while the power supply is on, otherwise you will get an electric shock.

You must put the cover of the terminals on the unit when you turn on the power and operate it.

The liquid crystal in the LCD panel is a hazardous substance. If the LCD panel is damaged, never swallow the leaked liquid crystal. If the liquid crystal spills on your skin or clothing, use soap and wash off thoroughly.



**CAUTION**

Hakko Electronics Co., Ltd. is not responsible for an unauthorized person who may fix, disassemble, or reconstruct any unit.

Avoid displaying the same patterns for hours. It may cause afterimages due to the property of LCD display. If you use the fixed patterns for hours, use the auto-OFF function of the backlight.

# Contents

---

## 1. Hardware Specifications

1. Special Features .....	1-1
2. Notes on Usage .....	1-2
3. System Composition .....	1-4
4. Names of Components .....	1-7
5. Dimensions and Panel Cut-out .....	1-8
6. Mounting Procedure .....	1-9
7. Specifications .....	1-10
8. Wiring of Power Supply .....	1-14
9. Serial Connector (CN1) .....	1-15
10. 1 : 1 Communications .....	1-19
11. 1 : n (Multi-drop) Communication .....	1-20
12. n : 1 (Multi-link 2, multi-link) .....	1-22
13. Modular Jack 1 & 2 .....	1-26
14. Setting of Dip Switches .....	1-27
15. Barcode Reader Interface .....	1-28
16. Printer Interface (CN2) .....	1-29
17. Specifications of SRAM & Built-in Clock .....	1-30

## 2. System Menu

1. Operation of Main Menu .....	2-1
2. Errors Caused on the V609E .....	2-11

## 3. Editing & Converting Screen

1. Screen Editing of V609E .....	3-1
Setting Procedure .....	3-1
Restrictions on Creating New Screens with V609E .....	3-2
2. GD-80E -> V609E Conversion .....	3-4
CONSIDERATIONS ON HARDWARE .....	3-4
CONSIDERATIONS ON SOFTWARE .....	3-6





# Hardware Specifications

---

1. Special Features
2. Notes on Usage
3. System Composition
4. Names of Components
5. Dimensions and Panel Cut-out
6. Mounting Procedure
7. Specifications
8. Wiring of Power Supply
9. Serial Connector (CN1)
10. 1 : 1 Communications
11. 1 : n (Multi-drop) Communication
12. n : 1 (Multi-link 2, multi-link)
13. Modular Jack 1 & 2
14. Setting of Dip Switches
15. Barcode Reader Interface
16. Printer Interface (CN2)
17. Specifications of SRAM & Built-in Clock



---

# 1 Special Features

---

## 1) High-intensity EL Display

Adopts the high-intensity EL device to ensure wide angle of field of view.

Can create easy-to-view screen thanks to orange-yellow display on black background color.

## 2) High-resolution switch mesh

Uses 40 (W) x 20 (H) touch switches adopting the matrix resistance film.

Allows setting and arranging of switches in a variety of styles.

## 3) Interface with GD-80E compatibility

Hardware and software designed with replacement of GD-80E (Monitor GD80 series, EL display type) taken into consideration ensure easy model change.

Inheriting the specifications such as 640 (H) x 400 (V) dot resolution, 8.9-inch screen size and panel cutout dimensions from GD-80E, V609E is released as user friendly high-level model to ensure smooth replacement of GD-80E.

For the connection to a PLC, the converter to maintain compatibility of wiring is optionally available.

## 4) Two built-in modular ports

As with V6 series, two built-in ports of modular jack are provided to ensure compatibility to wide range of functions such as temperature control network and multi-link 2.

\* **Please note that the maximum baud rate is 57,600 bps.**

# 2 Notes on Usage



## Environmental Limits

1. Use MONITOUCH at an ambient temperature of 0~50°C, and a relative humidity of 85 %RH.

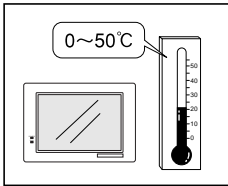

2. Install a forced fan or an air conditioner to maintain the ambient temperature when it is higher than the above mentioned range.

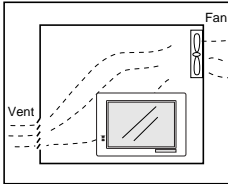

3. Avoid places where moisture may easily condense due to sudden temperature changes.

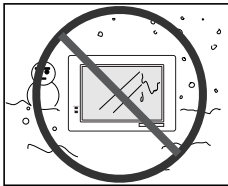

4. Avoid direct sunlight.

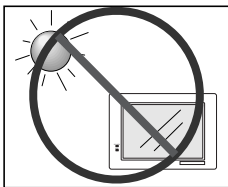

5. Never install MONITOUCH in a place where impacts or vibrations may be transmitted.

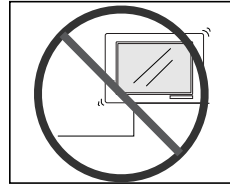

6. Avoid any place in which there is the possibility that water, corrosive gas, flammable gas, solvents, grinding fluids or cutting oil can come in contact with the unit. Never install the unit in a place where dust, salt and metallic particles are present.

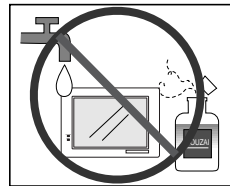

## Locations

1. Secure sufficient space around MONITOUCH for ventilation.

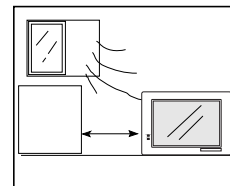

2. Never attach MONITOUCH to the top of any apparatus generating high levels of heat (heater, transformer, large-capacity resistor, etc.).





- Never install MONITOUCH in the same compartment as high-voltage equipment. The unit should be at least 200 mm away from high-voltage lines or power cables.

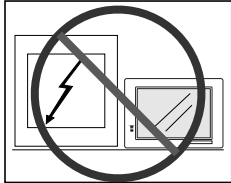

**Usage**

- An emergency stop circuit must be composed of an external relay circuit with a start signal for MONITOUCH built in. Do not create switches on MONITOUCH to be used in case of emergency.

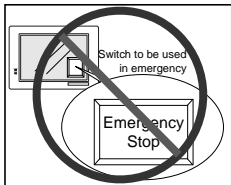

- In case of using a waterproof sheet (GD-WP80E), mount it in the unit by using 6 pieces of mounting screws (normally 4 pieces of them).
- MONITOUCH has a glass screen. Never drop or subject the unit to strong impacts.

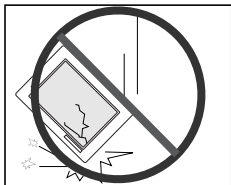

- Tighten mounting screws with the following torques.

Position of Screw	Screw Size	Torque (N · m)
Mounting Screw	M3	0.3-0.5 (3-5kgf · cm)

Note :Never fasten these screws too tightly, otherwise the cover of MONITOUCH may be deformed.

- In a dry environment, MONITOUCH may generate a large amount of static electricity. Therefore, before touching the unit, touch a grounded metallic section to discharge the static electricity.

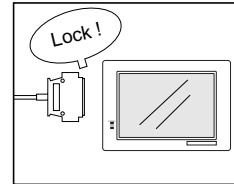

- Securely fasten and lock every connector for each cable. Double-check this before turning the power on.

- Application of thinner may discolor MONITOUCH. Use alcohol or benzene available commercially for cleaning.

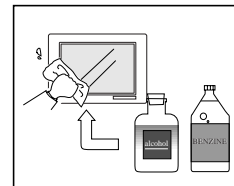

- Never remove any printed circuit board from MONITOUCH. (This will harm the unit.)

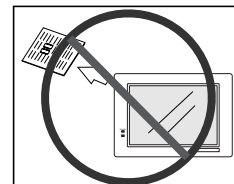

- Never operate the display by using a tool with a sharp point like a screwdriver. Touch the display by fingers.

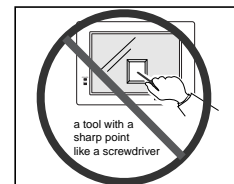

**Notes on Design**

- Use all the display area evenly and avoid using fixed patterns which may cause afterimages so that the life span of the display can be expanded.

# 3 System Composition

System Composition/Model Indication/Peripheral Equipment

## System Composition

The following illustration shows possible system configurations using V609E.

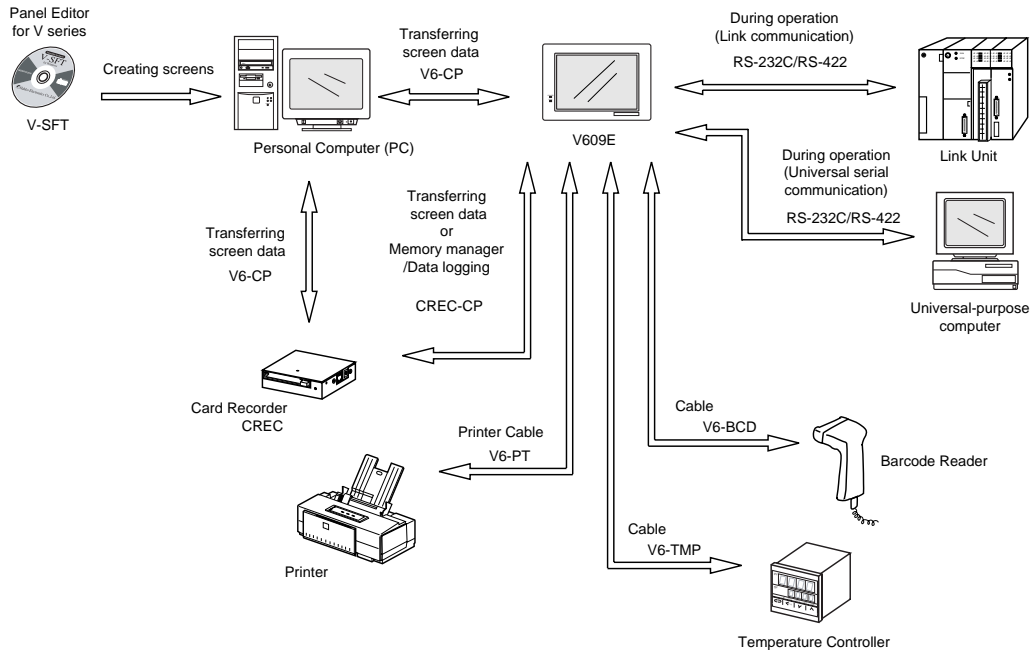

## Model Indication

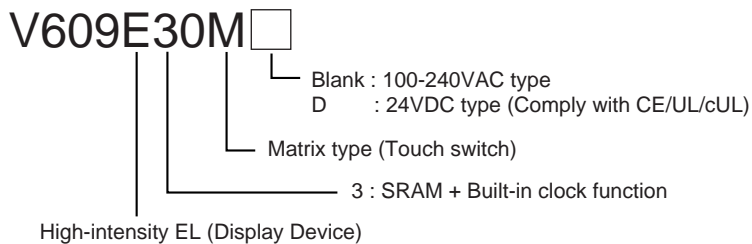

## Peripheral Equipment

The following options are available for using V609E more effectively.



### V-SFT (Panel Editor for Windows98/NT4.0/Me/2000/XP)

Application software for editing display data for V series.

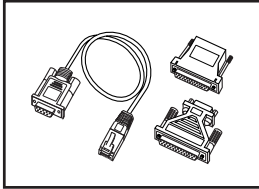

### V6-CP (Data Transfer Cable) 3m

Connects V6 to a personal computer, or a personal computer to CREC.

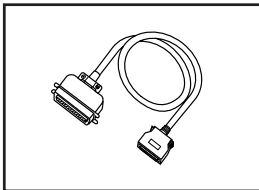

### V6-PT (Printer Cable) 2.5m

Connects V6 to a printer.

\* When using CBM292/293 printer, our printer cable "V6-PTCBM" is available.

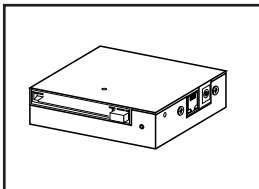

### CREC (Card Recorder)

Reads display data created by personal computer, or works as an external memory storage system for the memory manager and data logging functions.

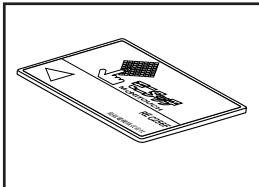

### REC-MCARD (Memory Card)

Complies with JEIDA Ver.4.0

Used as a recording medium for display data back-up and for the memory manager or data logging function.

SRAM 256K, 512K, 1M, 2M, 4Mbyte

FLASH ROM 256K, 512K, 1M



### M-CARD SFT (Memory Card Editor)

Application software for editing data stored in a memory card.

(For Windows98/NT 4.0/Me/2000/XP)

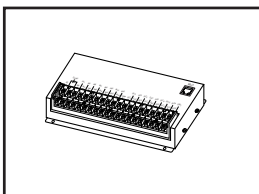

### V-I/O (Serial Extension I/O)

Used as an external I/O unit for PLC. It has 16 inputs and 16 outputs.

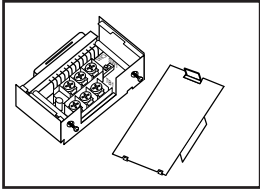

### TC485 (Terminal Converter)

Used for connection between a V6 and a PLC at the RS-422/485 terminal block.

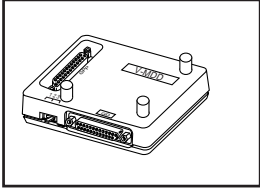

### V-MDD (ACPU/QnACPU/FXCPU Dual Port Interface)

Add-on connector with two ports, specifically designed for the connector on the MITSUBISHI's ACPU/QnACPU/FXCPU programmer. This can improve operability of the ACPU/QnACPU/FXCPU programmer that is directly connected.

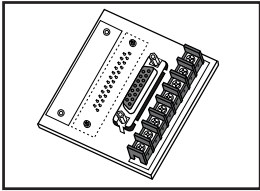

### TC609 (Terminal converter for V609E)

The communication board that allows the use of existing communication cable used with GD-80E.

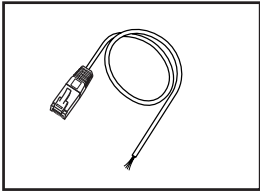

### V6-BCD (Cable for Barcode Reader) 3m

Connects V6 to a barcode reader.

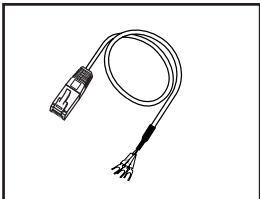

### V6-MLT (Cable for Multi-Link 2 master station) 3m

A cable which is used for connecting the V6 master station and the V6 slave station in the Multi-Link 2 connection.

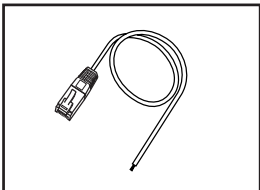

### V6-TMP (Cable for Temperature Controller) 3m

Connects V6 to a temperature controller.

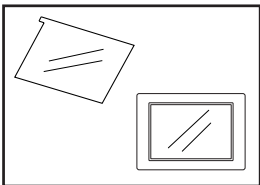

### GD-GS80E (Protection Sheet)

Protects the operation panel surface. Five sheets are included in one package.

### GD-WP80E (Waterproof Sheet)

Protects the operation panel surface from water.

# 4 Names of Components

## Front Side

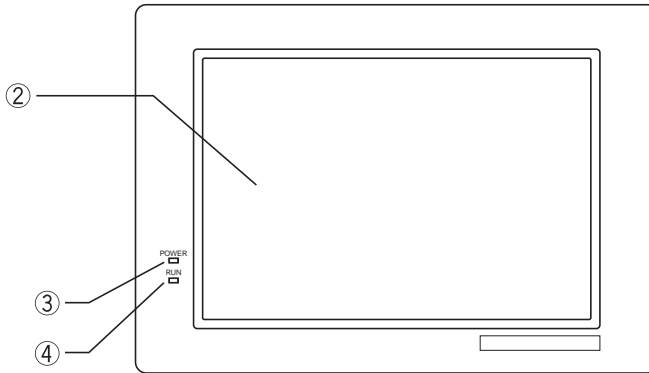

## Rear Side

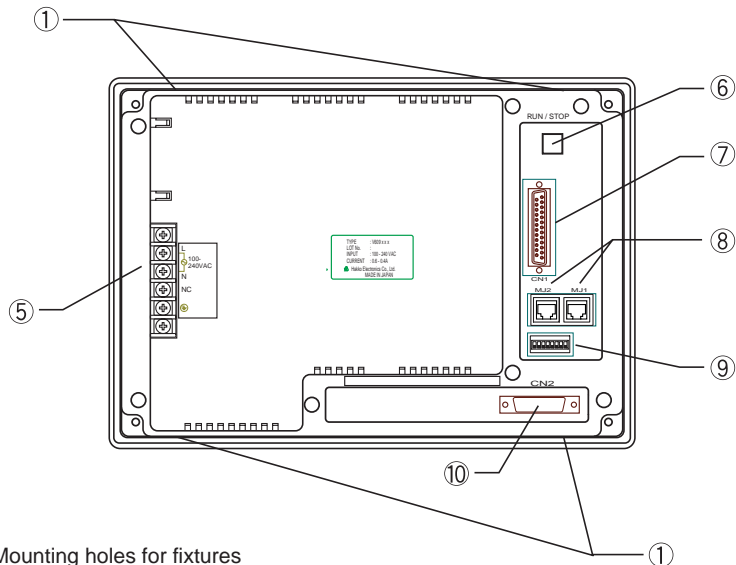

1. Mounting holes for fixtures
2. Display
3. Power lamp
4. RUN lamp
5. AC / DC input terminal of power supply
6. RUN/STOP switch
7. CN1: for PLC (RS-232C, RS-422)
8. MJ1, 2: for data transfer and for temperature controller and for barcode reader and for CREC (option)
9. Dip switches
10. CN2: for printer

# 5 Dimensions and Panel Cut-out

## Dimensions of V609E

Unit : mm

### ● Bottom View

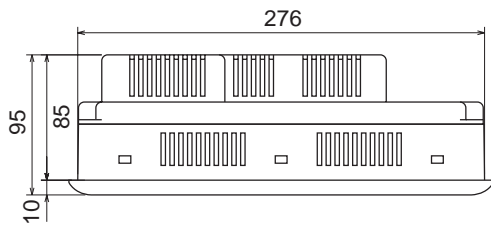

### ● Rear View

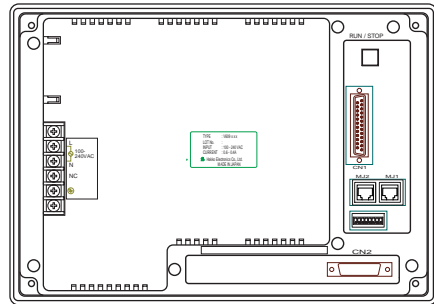

### ● Front View

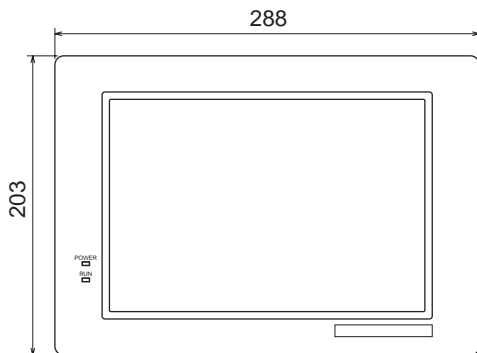

### ● Side View

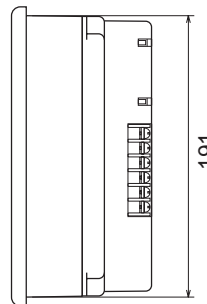

## Panel Cut-out of V609E

Unit : mm

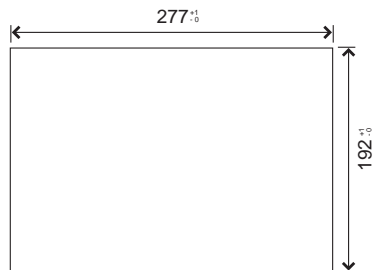

Panel Cut-out

# 6 Mounting Procedure

## Mounting Procedure

1. Cut out the mounting panel (Max. thick: 5 mm) to match the dimensions shown below.

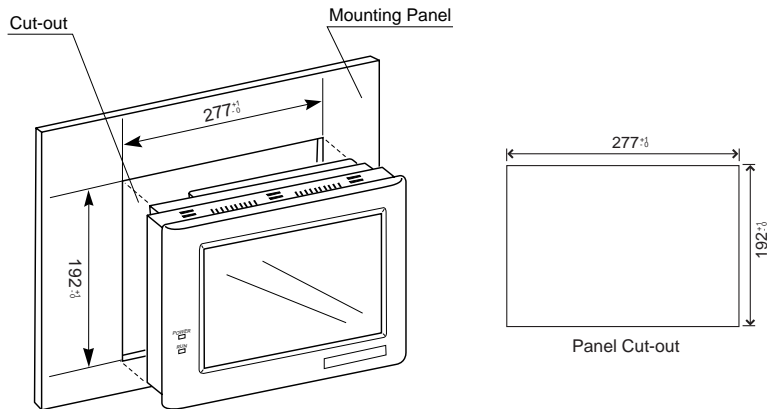

2. Insert 4 pieces of the fixtures attached to V609E into the mounting holes on V609E. Tighten them with the locking screws.

Screws : 4 pcs  
 Screw Size : M3  
 Torque : 0.3–0.5 N·m (3–5 kgf·cm)

\* Never use 6 pieces of the fixtures to mount V609E.

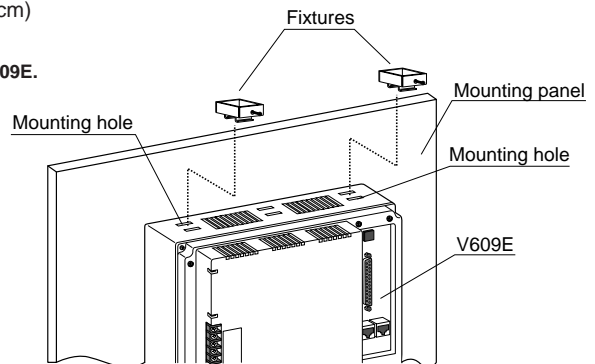
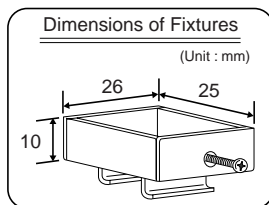

## Mounting Angle

The unit (V609E) shall be installed within the angle of 0 to 135 degrees as shown below.

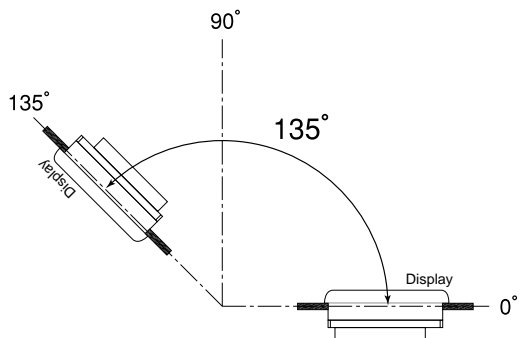

# 7 Specifications

## General Specifications

Item	Type	AC Power Supply	DC Power Supply
Power Supply	Rated Voltage	100-240V AC	24V DC
	Permissible Range of Voltage	85-265V AC (47-440Hz)	24V DC $\pm$ 10%
	Permissible Momentary Power Failure	within 20ms	within 10ms
	Demand	40VA or less	20W or less
	Rushed Electric Current	10A, 2ms	24A, 10ms
	With-stand Voltage	AC external terminals to FG : 1500V AC per min.	DC external terminals to FG : 500V AC per min.
Insulation Resistance		500V DC, 10M $\Omega$ or more	
Physical Environment	Ambient Temperature	0°C ~+50°C	
	Storage Ambient Temperature	-10°C ~+65°C	
	Ambient Humidity	85% RH or less (without dew condensation)	
	Dust	No conductive dust	
	Solvent Resistance	No cutting oil or no organic solvent to cling to the unit	
	Corrosive Gas	No corrosive gas	
Mechanical Working Conditions	Vibration Resistance	Vibration frequency: 10~150Hz, Acceleration: 9.8m/s <sup>2</sup> (1.0G) 3 directions of X, Y and Z: one hour	
	Shock Resistance	Pulse shape: Sine half wave, Peak acceleration: 147m/s <sup>2</sup> (15G), 3 directions of X, Y and Z: 2 times	
Electrical Working Conditions	Noise Resistance	1500Vp-p (noise width: 1 $\mu$ s)	
	Static Electricity Discharge Resistance	Contact: 6kV, Air: 8kV	
Mounting Conditions	Grounding	Grounding resistance: less than 100 $\Omega$	
	Structure	Protection structure: front panel complies with IP64 (when using waterproof screen filter GD-WP80E) rear panel complies with IP20  Form: in a body  Mounting procedure: inserted in a mounting panel	
	Cooling System	Cooling naturally	
	Weight	Approx. 2.1kg	
	Dimensions W x H x D (mm)	288 x 203 x 95	
	Panel Cut-out (mm)	277 <sup>+1</sup> <sub>-0</sub> x 192 <sup>+1</sup> <sub>-0</sub>	
	Case Color	GREY	BLACK
Material	ABS	PC/PS	



## Display Specifications

Item	Type	V609E
Display Device		High-intensity EL
Resolution W x H (dots)		640 x 400
Dot Pitch W x H (mm)		0.3 x 0.3
Effective Display Area W x H (mm)		192 x 120 (8.9 inches)
Color		Black/orange-yellow + blinking
POWER Lamp (red)		The lamp is lit when the power is supplied.
RUN Lamp (green)		The lamp is lit when V6 communicates with PLC normally.

## Display Function Specifications

Item		Specifications				
Display Language *		Japanese	Eng./W. Europe	Chinese	Chinese (simplified)	Korean
Characters	1/4-size, 1-byte	ANK code	Latin 1	ASCII code	ASCII code	ASCII code
	2-byte (16-dot)	JIS 1st and 2nd	_____	Chinese	Chinese (simplified)	Hangul (without Kanji)
	2-byte (32-dot)	JIS 1st	_____			
Size of Characters		1/4-size : 8 X 8 dots 1-byte : 8 X 16 dots 2-byte : 16 X 16 dots or 32 X 32 dots Enlarge : W, 1-8 H, 1-8				
Number of Characters		1/4-size	80 columns X 40 lines			
		1-byte	80 columns X 20 lines			
		2-byte	40 columns X 20 lines			
Property of Characters		Display property : normal, reverse, blinking, bold, shadow Color : black/orange-yellow + blinking				
Kind of Drawing		Lines : line, continuous lines, box, parallelogram, polygon Circles : circle, arc, sector, ellipse, elliptical arc, elliptical sector Others : tile patterns				
Property of Drawing		Type of lines : 6 types (fine, thick, dot, chain, broken, two-dot chain) Tile patterns : 16 types (incl. user-definable 8 types) Display property : normal, reverse, blinking Display color : black/orange-yellow + blinking Color specification : foreground, background, boundaries (line)				

\* Concerning Gothic font, use of this font is not recommended since the V609E screen memory capacity (see the next page) could not be sufficient.

## Function Performance Specifications

Item		Specifications
Screens		Max. 1024
Screen Memory		FP-ROM (flash ROM), Appox. 760kbytes (different from the language)
Switches		192 per screen
Actions of Switch		Set, reset, momentary, alternate, to light (possible to press a function switch and a display switch at the same time)
Lamps		Reverse, blinking, exchange of graphics 192 per screen
Graphs		* Pie, bar, panel meter and closed area graph can be displayed without limit. Total capacity per screen: within 48kB Statics and trend graphs: Max. 256 per layer
Data Setting	Numerical Data Display*	No limits, total capacity per screen: within 48 kB
	Character Display *	No limits, total capacity per screen: within 48 kB
	Message Display *	Resolution : Max. 80 characters No limits, total capacity per screen: within 48 kB
Messages		6144 lines
Sampling		Sampling display of buffer data (constant sample, bit synchronize, bit sample, relay sample, alarm function)
Multi-Overlaps		Max. 1024
Data Blocks		Max. 1024
Graphic Libraries		Max. 2560
Patterns		Max. 1024
Macro Blocks		Max. 1024
Page Blocks		Max. 1024
Direct Blocks		Max. 1024
Screen Blocks		Max. 1024
Temperature Control Network Table		Max. 32
Calendar		provided
Hard-Copy		provided
Buzzer		provided, 3 types (intermittent short, long, continuous beeps)
Back-light Auto OFF Function		ON at all time, specified freely
Self-diagnostic Function		Self-test function of switches Check function of communication parameter setting Check function of communication

\* Number of the setting memory per screen: 256

## Touch Panel Specifications

Item	Specifications
Switch Resolution	40 (W) X 20 (H)
Form	Matrix resistance film form
Life of Touch Panel	Use of one million times or more
Surface treatment	Hard coating, anti-glare treatment 5%

## Interface Specifications

Item	Specifications
Serial Interface for connecting PLC (D-sub 25 pins, female)	RS-232C, RS-422/485 Asynchronous type Data length: 7, 8 bits Parity: even, odd, none Stop bit: 1, 2 bits Baud rate: 4800, 9600, 19200, 38400, 57600bps
Serial Interface 1 and 2 for transferring data/barcode /CREC (modular jack, 8 pins)	RS-232C, RS-422/485 (2-wire connection) *When CREC, an optional equipment, is connected: 1 slot SRAM: Max. 4 MB FROM: Max. 16 MB Comply with JEIDA Ver. 4.0 (The limit exists.)
Printer Interface	Complies with centronics, half pitch 36 pins (for PC98x1) NEC : PR201 EPSON : compatibles with ESC/P24-84 or later HP : PCL Level 3 CBM292/293 printer (The screen copy cannot be printed out.) MR-400 printer (The hard copy, data sheet and sampling data cannot be printed out.)

## Drawing Environment

Item	Specifications
Drawing Method	Exclusive drawing software
Drawing Tool	Name of exclusive drawing software : V-SFT Ver. 1.2.18.0 or later Personal computer : Pentium II 450MHz or more is recommended OS : Microsoft Windows 98/NT version 4.0/Me/2000/XP Capacity of hard disk required : free area of approx. 460MB or more (For minimum installation : Approx. 105MB) Display : Resolution of 800 X 600 or more is recommended

# 8 Wiring of Power Supply

## Electrical Wiring

- Connects the cable for power supply to the terminal on the rear side of V609E.

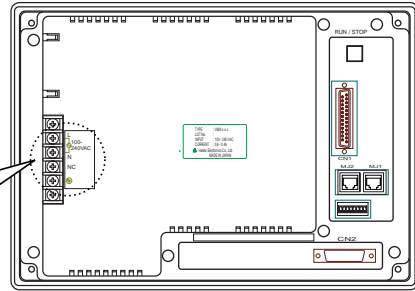
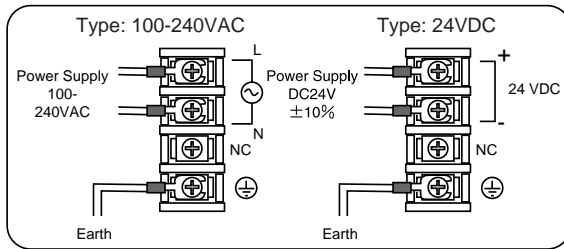

V609E

Screw Size	Torque (N · m)	Clamp Terminal (Unit : mm)
M3.5	0.5 (5kgf · cm)	8.0MAX  8.0MAX

- The power source used must be within the allowable voltage fluctuation.
- Use a power source with low noise between the cables or ground and the cable.
- Use as thick a power cable as possible to minimize any drop in voltage.
- Keep cables of 100V AC and 24V DC sufficiently away from high-voltage, large-current cables.

## Notes on Usage of 100-240V AC Specifications

- Generally, an isolating transformer improves noise resistance. However, if the display unit is far away from the secondary port of the transformer and noise gets mixed in, an isolating transformer becomes unnecessary.
- If any power voltage fluctuation caused by noise is expected, it is recommended that a voltage stabilizer (effective in noise resistance) be used.

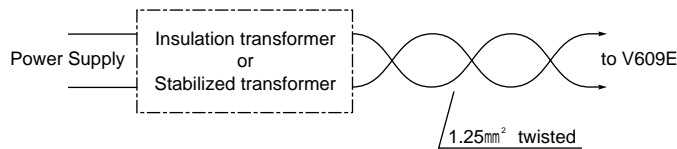

## Grounding



**This equipment must be earthed.**

- An independent earth pole shall be used for MONITOUCH. (The level of grounding resistance should be less than 100 Ω.)
- Use a cable which has a nominal cross section of more than 2mm<sup>2</sup> for grounding.
- Grounding point shall be near the MONITOUCH to shorten the distance of grounding wires.

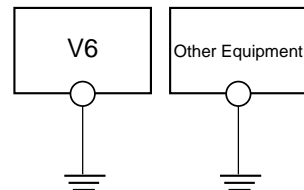

# 9 Serial Connector (CN1)

CN1 is used for communicating between a PLC and a V609E (RS-232C, RS-422/485).

## Interface Specifications

Item	Specifications
Serial Interface for connecting PLC (D-sub 25 pins, female)	RS-232C, RS-422/485 Asynchronous type Data length: 7, 8 bits Parity: even, odd, none Stop bit: 1, 2 bits Baud rate: 4800, 9600, 19200, 38400, 57600bps

## Serial Connector (CN1)

The pin arrangement of serial connector is as follows:

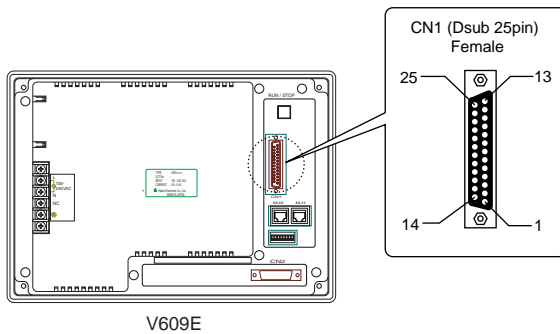

Pin No.	Signal	Contents
1	FG	Frame ground
2	SD	RS-232C send data
3	RD	RS-232C receive data
4	RS	RS-232C RS request to send
5	CS	RS-232C CS clear to send
6		Not used
7	SG	Signal ground
8		Not used
9	+5V	Use prohibited
10	0V	Use prohibited
11		Not used
12	+SD	RS-422 send data (+)
13	-SD	RS-422 send data (-)
14	+RS	RS-422 RS send data (+)
15		Not used
16		Not used
17	-RS	RS-422 RS send data (-)
18	-CS	RS-422 CS receive data (-)
19	+CS	RS-422 CS receive data (+)
20		Not used
21		Not used
22		Not used
23		Not used
24	+RD	RS-422 receive data (+)
25	-RD	RS-422 receive data (-)

### Wiring for Communication

- Never place the communication cable with electric circuits.
- Never bundle these cables together with other wires in ducts or electric boxes using cord locks. Although it is tempting to bundle all the cables neatly together, this does not necessarily lead to a noise-resistant configuration.
- It is recommended that the communication cable be independently wired.

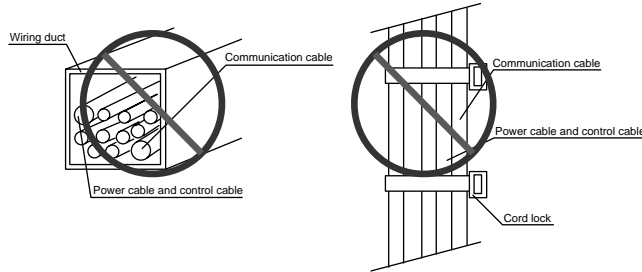

### In Case of RS-232C Communication

- In case of RS-232C, SD and SG, and RD and SG form a pair.
- Connect the shielded cable to pin No. 1 or the connector case cover.

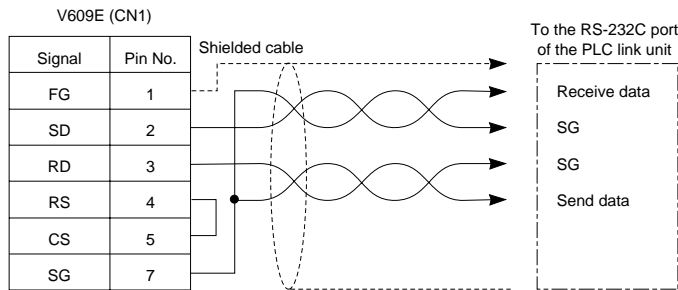

### In Case of RS-422 Communication

- In case of RS-422, +SD and -SD, and +RD and -RD form a pair.
- Use SG if possible.
- Connect the shielded cable to pin No. 1 or the connector case cover.
- Use TC485 or TC609 which is the optional equipment made by Hakko Electronics Co., Ltd. in case of using terminal blocks in RS-422/485 connection.
- Specify terminal resistance by the dip switches on V6. (Refer to the next page.)

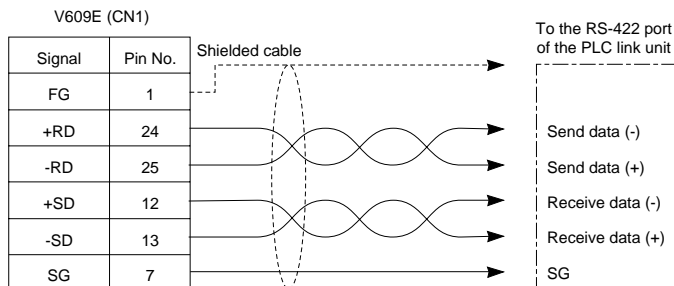

## Terminal Blocks of RS-422/485

- Connect TC485 (Terminal Converter) which is the optional equipment made by Hakko Electronics Co., Ltd. to V6 via the serial connector on V609E (CN1) in case of using terminal blocks in RS-422/485 connection.
- The RS-422 signal wiring of TC485 is connected to the serial connector (CN1).
- Specify 4-wire connection or 2-wire connection by the dip switch on TC485 (SW1).  
(set to top: 4-wire connection)

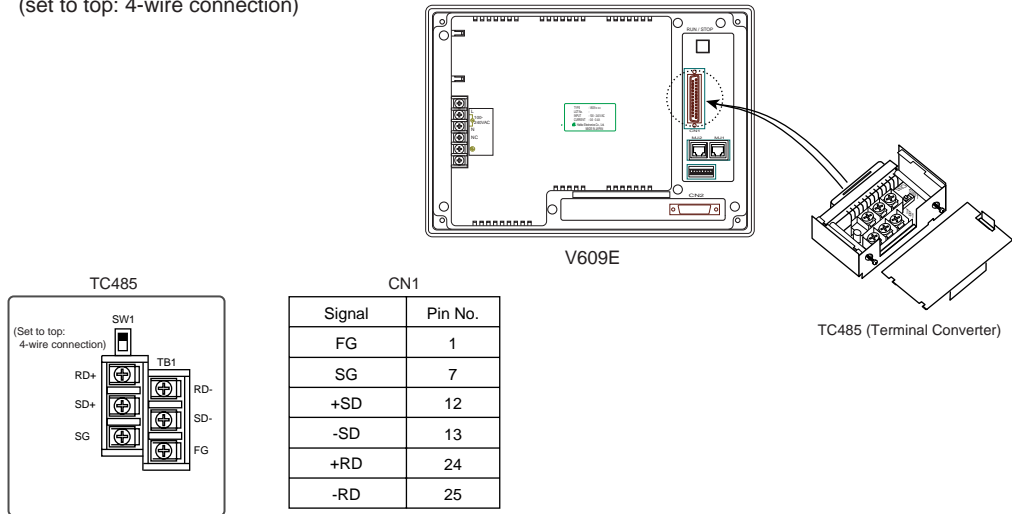

## Terminal Converter (TC609) for V609E

- To use the existing wiring, used for GD-80E, when replacing GD-80E with V609E, connect the TC609 (Terminal Converter for V609E), optional equipment made by Hakko Electronics Co., Ltd. to the serial connector (CN1).
- Signal wiring of D-sub 15 pins and RS-422 terminal block of TC609 is connected to the serial connector (CN1).
- D-sub 15 pin port of TC609 is equivalent to the connector on GD-80E where CPU port direct connection cable (MB-CPU) for Mitsubishi A/QnA/Fx series is connected. The RS-422 terminal block of TC609 is equivalent to the RS-422 terminal block of standard specification GD-80E.

\* For details, refer to "User's Manual of TC609 (Terminal Converter for V609E)."

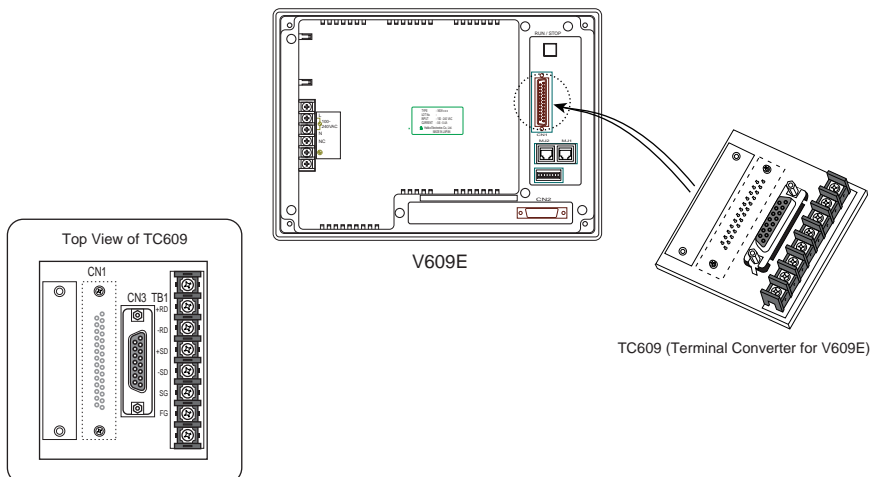

### Connection Style

Three kinds of V609E to PLC connection styles are available as shown below.

○ 1 : 1

In this style, a single V609E is connected to a single PLC.  
For details, refer to "10 1 : 1 Communications."

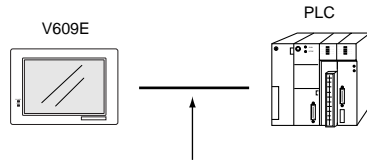

To be connected through RS-232C or RS-422 (RS-485) interface.

○ 1 : n (multi-drop)

In this style, multiple PLCs are connected to a single V609E. (n = 1 to 31)  
For details, refer to "11 1 : n Communications."

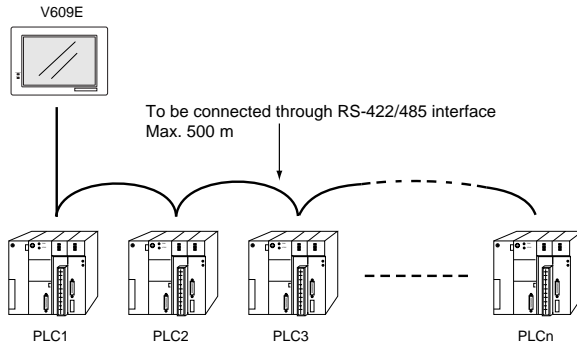

○ n : 1 (multi-link 2, multi-link)

In this style, multiple V6s are connected to a single PLC.  
(Multi-link 2: n = 1 to 4, Multi-link: n = 1 to 31)  
For details, refer to "12 n : 1 (multi-link 2, multi-link)."

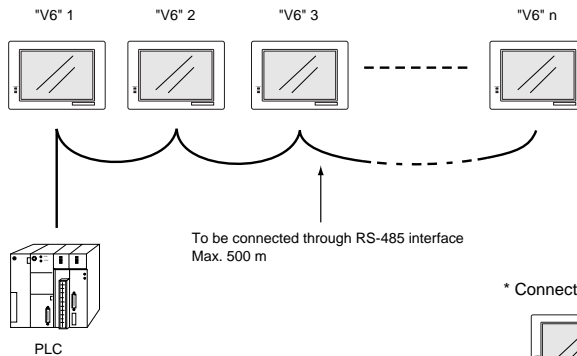

\* Connection as show below is not recommended.

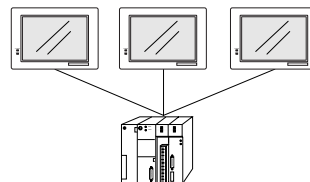



# 10 1 : 1 Communications

In this style, a single V609E is connected to a single PLC.

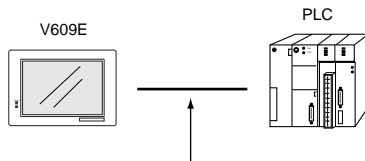

To be connected through RS-232C or RS-422 (RS-485) interface.

## Connection to a PLC

About the wiring, communication parameter, etc. in connection between V609E and a PLC, refer to 'Chapter 2 Connection to Link Units' of "V6 Hardware Specifications."

# 11 1 : n (Multi-drop) Communication

One V6 and multiple PLCs are connected. (n = 1 to 31)

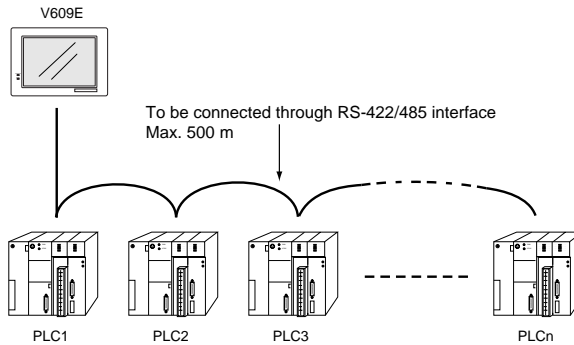

## Available PLC for multi-drop communication

Manufacturer	Models
MITSUBISHI ELECTRIC	A series link, QnA series link, QnH(Q) series link, Alink+Net10, FX series link(A prt)
OMRON	SYSMAC C, SYSMAC CV, SYSMAC CS1/CJ1, SYSMAC CS1/CJ1 DNA
SHARP	JW series, JW100/70H COM port, JW20 COM port
Hitachi	HIDIC-H
Matsushita Electric Works	MEWNET
Yokogawa Electric	FA500, FA-M3, FA-M3R
Yaskawa Electric	MEMOBUS, CP9200SH/MP900
Toyoda Machine Works	TOYOPUC
Fuji Electric	MICREX-F series, FLEX-PC series, FLEX-PC COM(T)
KOYO ELECTRONICS	SU/SG, SR-T
Allen-Bradley	PLC-5, SLC500, Micro Logix 1000
GE Fanuc	90 series
TOSHIBA	T series
Siemens	S7-200 PPI, S7-300/400MPI*
SHINKO ELECTRIC	SELMART
SAMSUNG	SPC series, N_plus, SECNET
KEYENCE	KZ series link, KZ/KV series CPU
LG	MASTER-K500/1000, MASTER-KxxxS CNET, GLOFA CNET
FATEK AUTOMATION	FACON FB series
IDEC	MICRO3, MICRO Smart
MODICON	Modbus RTU
TAIAN	TP02
	Universal Serial

\* Up to 4 PLCs can be connected.

## Multi-drop Communication (RS-422)

Refer to the PLC manual of each manufacturer for connection.

<E.g.>

The following example describes how one V609E is connected to three PLCs made by MITSUBISHI.  
See MITSUBISHI's manual for further details.

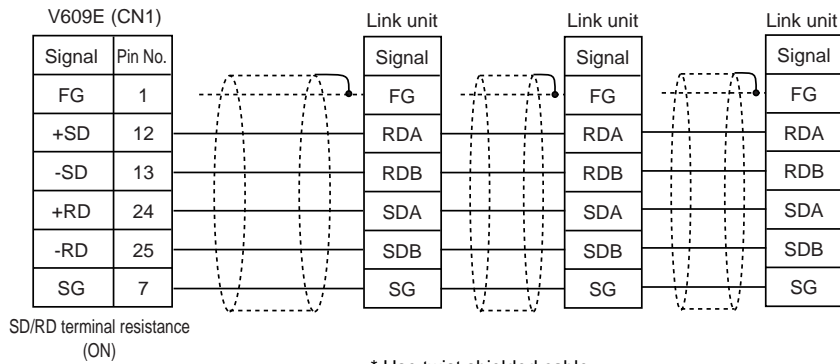

# 12 n : 1 (Multi-link 2, multi-link)

Multiple V6s are connected to a single PLC.  
In this style, there are two kinds of communications.

## n : 1 Link Communication (Multi-link2)

○ Up to 4 units can be connected to one PLC.

\* Between a PLC and the V6 master station is the same as those for 1:1 communication.

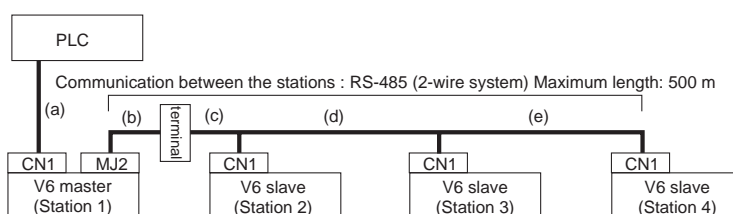

○ Available PLCs for multi-link2.

As of December 2003, the PLCs supported are as follows. All the PLCs which are usable for 1:1 communication will be supported.

Manufacturer	Models
MITSUBISHI ELECTRIC	A series link, A series CPU, QnA series link, QnA series CPU, QnH(Q) series link, QnH(A) series CPU, QnH(Q) series CPU, Q00J/00/01 CPU, FX series CPU, FX2N series CPU, FX1S series CPU, FX series link(A prt)
OMRON	SYSMAC C, SYSMAC CV, SYSMAC CS1/CJ1
SHARP	JW series, JW100/70H COM port, JW20 COM port
Hitachi	HIDIC-H, HIDIC-S10/2alpha, HIDIC-S10/ABS
Matsushita Electric Works	MEWNET
Yokogawa Electric	FA500, FA-M3, FA-M3R
Yaskawa Electric	MEMOBUS, CP9200SH/MP900
Toyoda Machine Works	TOYOPUC
Fuji Electric	MICREX-F series, MICREX-F series V4, FLEX-PC series, FLEX-PC CPU, FLEX-PC COM(T), FLEX-PC series(T), FLEX-PC CPU(T)
KOYO ELECTRONICS	SU/SG, SR-T, SR-T(K prt), SU/SG(K-Sequence)
Allen-Bradley	PLC-5, SLC500, Micro Logix 1000, Control Logix
GE Fanuc	90 series, 90 series(SNP-X)
TOSHIBA	T series, EX series
TOSHIBA MACHINE	TC200
Siemens	S5, S5 PG port, S5 V4, S7, S7-300MPI(HMI ADP), S7-300MPI(PC ADP), S7-300MPI(Helmholz SSW7 ADP), TI500/505, TI500/505 V4
SAMSUNG	SPC series, N_plus, SECNET
KEYENCE	KZ series link, KZ-A500 CPU, KZ/KV series CPU, KZ24/300 CPU, KV10/24 CPU, KV-700 CPU
LG	MASTER-K10/60/200, MASTER-K500/1000, MASTER-KxxxS, MASTER-KxxxS CNET, GLOFA CNET, GLOFA GM series CPU
FANUC	Power Mate
FATEK AUTOMATION	FACON FB series
IDEC	MICRO3, MICRO Smart
MODICON	Modbus RTU
Yamatake	MX series, DMC50
TAIAN	TP02

For the I/F driver, the Multi-Link 2 is supported by the version of 1.100 or later and as for a V6 master station, make sure the hardware version of the unit is as follows. As for V609E/V606/V606i, any version can be used.

- Analog type: V612T --> D, V612C --> C, V610S --> D, V610T --> D, V610C --> C, V608C --> F
- Matrix type : All version

\* When V609E (or V606/V606i) is used as a master, V6 models that can be connected as a slave are only V609E, V606 and V606i.

\* The Multi-Link 2 cannot be used in Temperature control network.

- Up to 4 units can be connected to one PLC.

Use the terminal converter (TC485), the optional equipment made by Hakko Electronics Co., Ltd.  
See Multi-link2 manual for further details.

\* Wire the shielded FG only at the one of both sides so that they are not connected.

- Set the dip switch (SW1) of TC485 as 2-wire connection when the TC485 terminal converter is used.

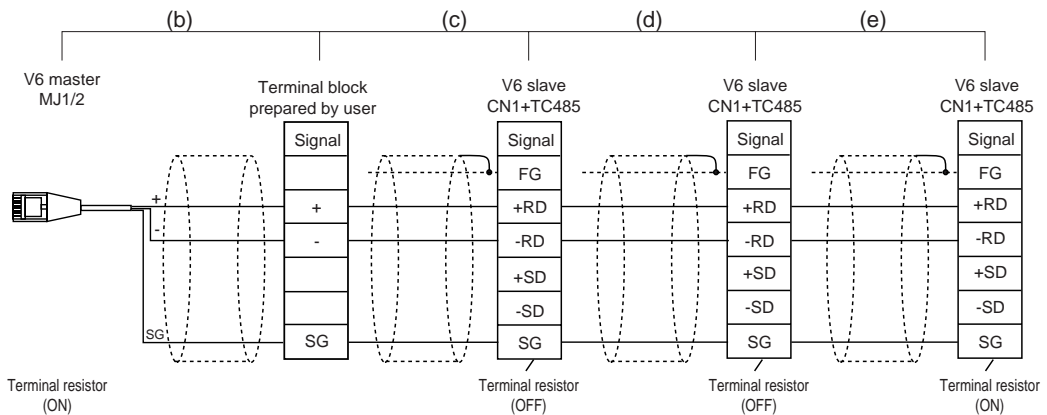

- Short-circuit between +RD and +SD, and -RD and -SD when the TC485 terminal converter is not used.

## n : 1 Link Communication (Multi-link)

- Multiple V6 and a PLC are connected. (n=1 to 31)

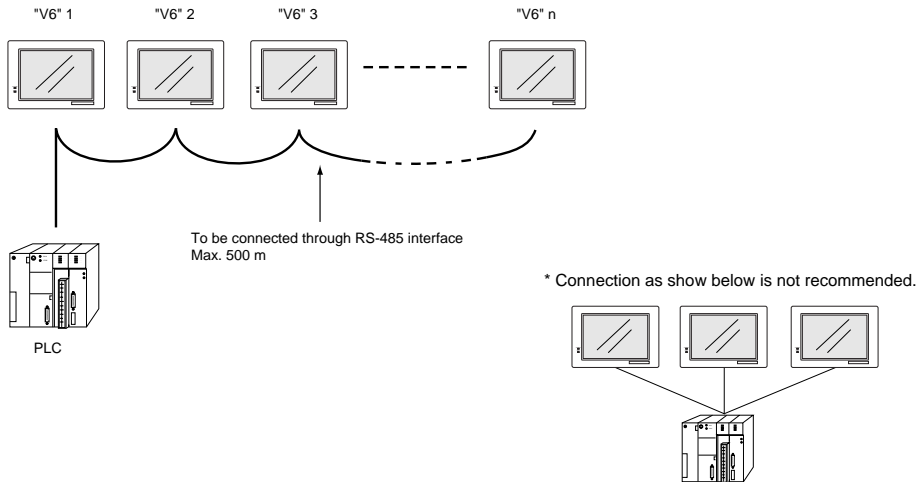

- Available PLCs for multi-link

Manufacturer	Models
MITSUBISHI ELECTRIC	A series link, Alink+Net10, FX series link(A prt), QnA series CPU (with V-MDD)
SHARP	JW series, JW100/70H COM port, JW20 COM port
Hitachi	HIDIC-H
Matsushita Electric Works	MEWNET
Yokogawa Electric	FA500, FA-M3, FA-M3R
Toyoda Machine Works	TOYOPUC
Fuji Electric	MICREX-F series, FLEX-PC COM(T)
TOSHIBA	T series
TOSHIBA MACHINE	TC200
Siemens	S7-200 PPI, S7-300/400MPI*
SHINKO ELECTRIC	SELMART
SAMSUNG	SPC series, N_plus, SECNET
LG	MASTER-K500/1000

\* Up to 3 units can be connected to one PLC.

- When multiple V6 are connected to a link unit of PLC, use the terminal converter (TC485), the optional equipment made by Hakko Electronics Co., Ltd. for RS-485 connection.

- Set the dip switch (SW1) of TC485 as 2-wire connection when the TC485 terminal converter is used.

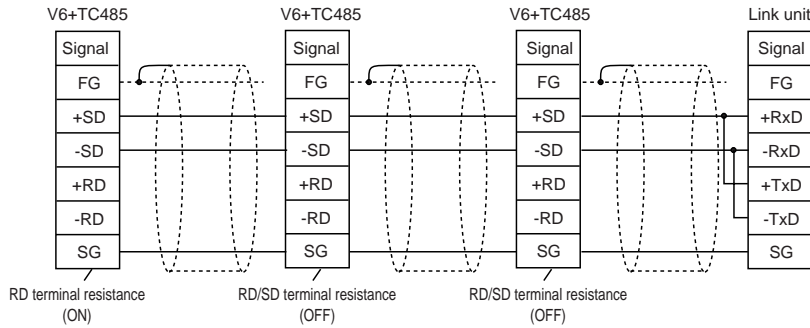

\* Use twist shielded cable.

- Short-circuit between +RD and +SD, and -RD and -SD when the TC485 terminal converter is not used.

- When multiple V6 are connected directly to MITSUBISHI's QCPU port, the optional equipment, V-MDD is required. Make sure to use V-MDD GD port. (It is recommended to use "TC485 Terminal Converter" which is an optional equipment made by Hakko Electronics Co., Ltd..)

- Set the dip switch (SW1) of TC485 as 2-wire connection when the TC485 terminal converter is used.

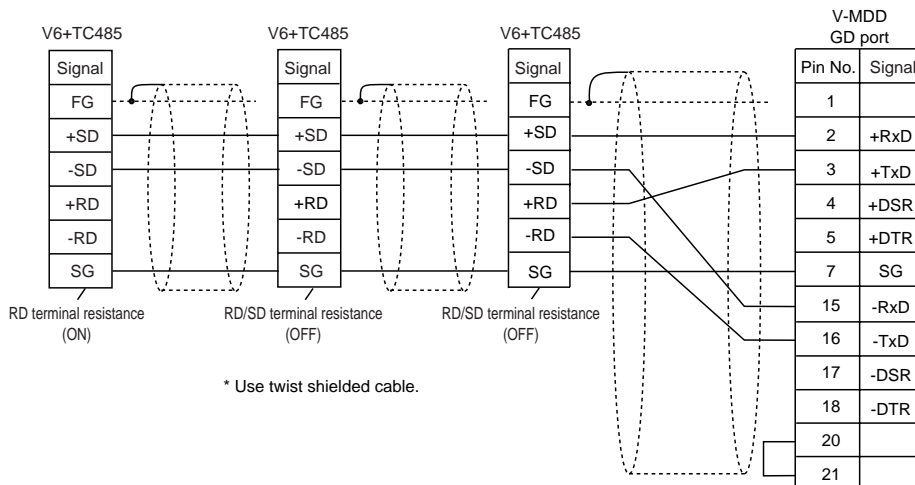

- Short-circuit between +RD and +SD, and -RD and -SD when the TC485 terminal converter is not used.

# 13 Modular Jack 1 & 2

## Modular Jack 1 & 2 (MJ1/2)

The right diagram is the pin arrangement and the signal name of modular jack 1 & 2.

MJ1/2	Pin No.	Signal
	1	+SD/RD
	2	-SD/RD
	3	+5V
	4	+5V
	5	0V
	6	0V
	7	RD
	8	SD

Output power supply  
Max. 150mA

## Setting of Modular Jack 1 & 2 (MJ1/MJ2)

- Specify the use of MJ1/MJ2 by the software (V-SFT).
- Select [Modular] of [System Setting], and then the [Modular Jack] dialog is displayed. The setting items of [Modular Jack 1] and [Modular Jack 2] in this dialog are as follows.

Modular Jack 1	Modular Jack 2
[Editor port]	[Not used]
[Memory Card]	[Memory Card]
[Barcode]	[Barcode]
[V-I/O]	[V-I/O]
[Multi-Link] *	[Multi-Link] *
[Temp./ PLC2Way]	[Temp./ PLC2Way]
[V-Link]	[V-Link]
[Modbus Slave]	[Modbus Slave]
[Printer(Serial Port)]	[Printer(Serial Port)]

It is impossible to select both [Multi-Link] and [Temp./ PLC2Way] in each setting of modular jack.

\* It is possible to select this item when [Multi-Link 2] is selected for [Connection] and [Local Port] is set to [1] in the [Comm. Parameter] dialog.

## Editor Transferring

- Use modular jack 1 (MJ1) in case of editor transferring.
- When [Editor port] is selected for [Modular Jack 1] in the [Modular Jack] dialog, it is also possible to transfer the data while running, because the auto change of the local mode and the run mode is valid. When [Editor port] is selected, on-line editing and the simulation mode are also available.
- When the item other than [Editor port] is selected for [Modular Jack 1] in the dialog, be sure to transfer the data by the software in the local mode. On-line editing and the simulation mode are not available.
- When the data is transferred by software, use the cable for data transferring which is the optional equipment made by Hakko Electronics Co., Ltd. (V6-CP: 3m) to connect V609E to a personal computer.



# 14 Setting of Dip Switches

## Setting of Dip Switches

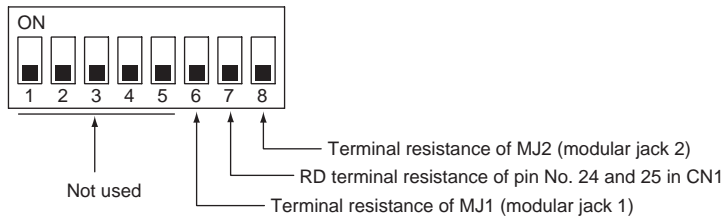

### ○ Setting of Terminal Resistance

- Set DIPSW 7 ON in case of connecting V6 to PLC by RS-422/485.
- Set DIPSW 6 (DIPSW 8) ON in case of connecting with Modular Jack 1/2 by the connection as shown below.

Multi-link 2 communication (master)

Temp./ PLC2Way communication by connection of RS-485

Card Recorder : CREC (option) is used

Serial Extension I/O : V-I/O (option) is used

Terminal V609E connected with V-Link by connection of RS-485

- Keep DIPSW 1, 2, 3, 4, 5 and 8 (not used) OFF.

# 15 Barcode Reader Interface

○ It is possible to receive the signal from a barcode reader by connecting a barcode reader to V609E via the modular jack (MJ1/MJ2) of V609E.

○ To connect a barcode reader to V609E via MJ1/MJ2, use the cable which is the optional equipment made by Hakko Electronics Co., Ltd. (V6-BCD).

Length : 3m

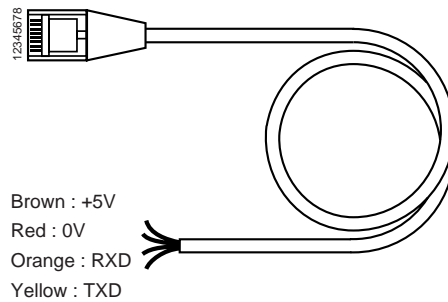

## ◎ Notes on Connection

- In case of using the barcode reader which uses the CTS and RTS control, the barcode reader may not work normally without jumping RTS and CTS.
- The output power supply (+5V) is max. 150mA. (Refer to page 1-26.)

○ When the barcode reader connected to GD-80E is used, connect it to V609E by the following cable.

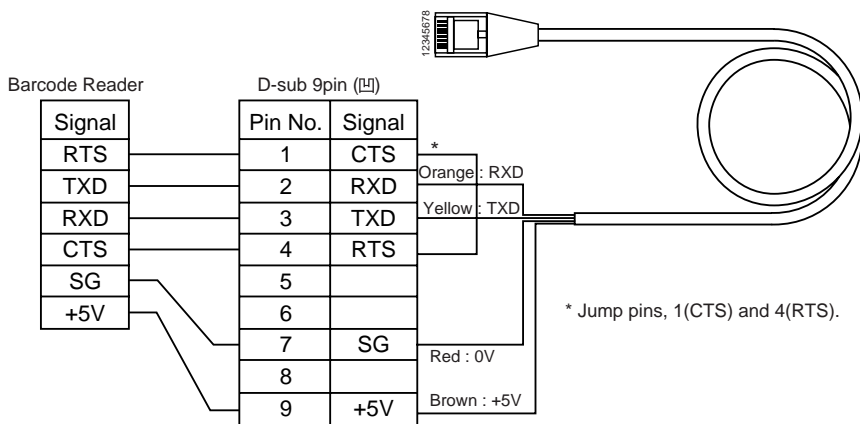

# 16 Printer Interface (CN2)

- When a printer is connected to V609E via the connector (CN2), it is possible to hard-copy the screen display of V609E, the data sheet, or the sampling data.
- To connect a printer to V6, use the parallel interface cable of 36 pins which is optional equipment made by Hakko Electronics Co., Ltd. (V6-PT: 2.5m)  
When using CBM292/293 printer, our printer cable “V6-PTCBM” is available.  
**\* The printer cable for GD-80 or V4 cannot be used.**

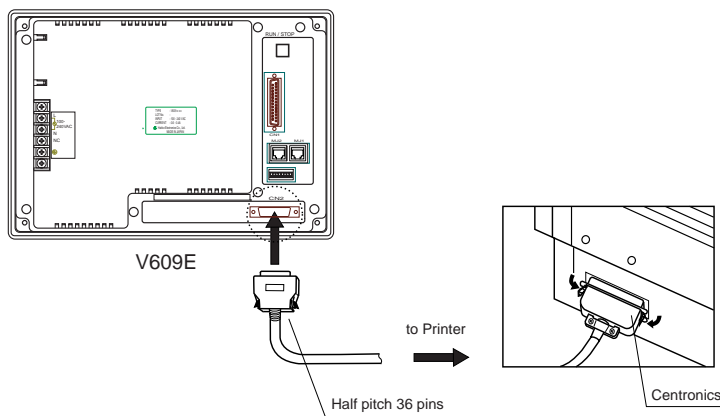

- Compatible Printer Control Code System and Printer Models
 

NEC	PC-PR201 series
EPSON	Compatibles with ESC/P24-84 or later
HP(HEWLETT PACKARD)	PCL Level 3
CBM292/293	Line thermal panel printer made by CBM Corporation (The screen copy cannot be printed out.)
MR400	Barcode printer [MR400 series] made by Sato Corporation (The hard copy, the data sheet, and the sampling data cannot be printed out.)

### Note of Usage of SRAM Memory Card (via CREC);

In case of connecting a printer to V609E with a “REC-MCARD(Memory Card:SRAM)” at all times, be sure to turn off a printer at the same time when turning off V609E. If a printer is not turned off when V609E is turned off, the voltage will circulate from the power supply line of a printer to make the power consumption of SRAM cassette’s backup battery increase, and finally, the backup battery will consume drastically within a few months.

# 17 Specifications of SRAM & Built-in Clock

## Memory Specifications

Item	Specifications
Memory Type	SRAM
Memory Capacity	8kbytes

## Backup Specifications

Item	Specifications
Battery Specification	Lithium primary battery of coin type
	Battery model : CR2430 (SANYO)
Backup Period	5 years (at the temperature of 25°C)
Replacement	Available (battery is attached to a socket)
Detection of Voltage for Battery Lowering	Available (internal memories allocated)
Calendar Precision	Remainder on a month $\pm 90$ seconds (at the temperature of 25°C)

## Notes on Usage of SRAM & Clock Function

- Check if the battery is set when using SRAM or clock function. The contents of SRAM may not be maintained if the electric power for SRAM is cut off.  
(The factory-shipped configuration is with the battery set.)  
Refer to the next item, "How to Check the Battery," about the way to check the battery condition.
- Use the following versions of each program file:
  - V-SFT version 1.3.1.0 or later
  - System program version 1.510 or later
  - Font data version 1.210/1.140/1.000 or later

## How to Check the Battery

The battery is set in V609E30M when shipped from the factory.

The standard backup period (5 years) is written down in the section of the 'Battery replacement' of the caution seal on the rear side of V609E30M.

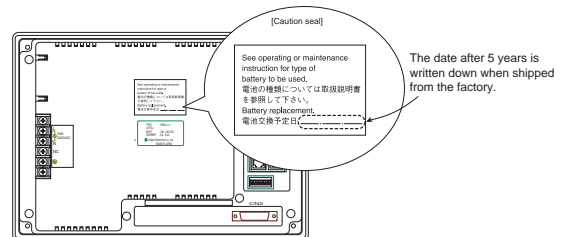

**\*The life of battery for V609E30M is about 5 years at 25°C. Even if 5 years don't pass, when the battery voltage has dropped, bit 4 of \$s167 is set (ON) to give an alarm about battery replacement. Replace the battery immediately then.**

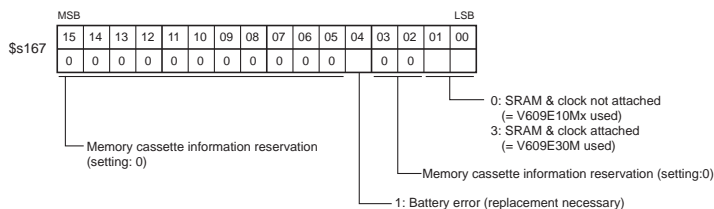

## How to Set SRAM and Clock

### ○ How to Set SRAM

Make sure if the battery is set before starting the following procedures.

1. Specify the necessary setting of the [SRAM/Clock Setting] in the [System Setting] when editing the screen data file.
2. Transfer the screen data file to V609E.
3. Pressing the [SRAM/Clock] switch of the [Main Menu] screen to the [SRAM/Clock Adjustment] screen, and execute the format of SRAM.

After that, the area of SRAM in V609E30M is to be available.

### ○ How to Set Clock

Make sure if the battery is set before starting the following procedures.

1. Check [Use Built-in Clock] of the [SRAM/Clock Setting] in the [System Setting] when editing the screen data file.
2. Transfer the screen data file to V609E.
3. Pressing the [SRAM/Clock] switch of the [Main Menu] screen to the [SRAM/Clock Adjustment] screen, and set the calendar.

After that, the clock function in V609E30M is to be available.

## Replacement of Battery

### ◎ Safety Precaution for Handling a Battery

The lithium battery encloses inflammable materials such as lithium and organic solvent. Therefore, wrong handling of the lithium battery may cause personal injury or fire. Thoroughly pay attention to the following cautions when handling the lithium battery to prevent unintended accidents.



### CAUTION

- Be sure and discharge the build-up of static electricity before installing, inspecting and maintaining the product.
- When replacing a battery, be sure and use the same battery as mentioned above. Use of another battery may prevent a risk of fire or explosion.
- The battery used in this device may present a fire or chemical burn hazard if mistreated.
- Do not disassemble, heat or incinerate the battery.
- When scrapping the spent battery, insulate the terminals with applying tape to them and follow local ordinances or regulations for its disposal.
- Keep away the battery from children. (Please immediately consult with a doctor if children have swallowed the battery.)
- Do not short-circuit.
- Do not charge.
- Do not solder directly on to batteries.
- Do not use the battery with the direction of +/- reversed.
- When the battery is leaking or giving out a foul smell, keep away the battery from fire right away, because there is the danger that the leaking electrolysis liquid is caught fire.

⊙ Safety Precaution for Handling V609E in Battery Replacement

Understand the procedure described in this manual before replacing the battery. Hakko Electronics assumes no responsibility for any accidents caused by failure to follow the replacement procedure in this manual



**DANGER**

- Turn off V609E before attempting to replace the battery. Set V609E aside until it cools. Failure to do so may result in an electric shock or burns.



**CAUTION**

- Wear gloves or fingerstalls when replacing the battery.
- Take necessary measures to protect V609E from static electricity.
- Do not touch cables and boards that are not associated with battery replacement. Doing so may result in failure.

○ How to Replace Battery

The battery for replacement is prepared.

Name	Model	Composition
V609E Battery for Replacement	V6EM/RB	<ul style="list-style-type: none"> <li>· Lithium primary battery of coin type 1 pce (SANYO CR2430)</li> <li>· A seal for caution 1 copy</li> </ul>

V609E can maintain the data in SRAM when the battery is replaced within 3 minutes after removing the original battery.

If it takes 3 minutes or more to replace the battery, save the data in SRAM by using V-SFT (cable: V6-CP) as follows.

1. Start the V-SFT.
2. Click the [Transfer] icon. The [Transfer] dialog is displayed.
3. Choose [Display] for [Transfer Device], and [SRAM Data] for [Transfer Data].
4. Click [PC<-] under [Transfer Mode].
5. The read data is to be stored in the “.RAM” file.

Replace the battery as follows:

1. Turn off V609E, and turn it upside down as follows. Remove the 4 external screws.

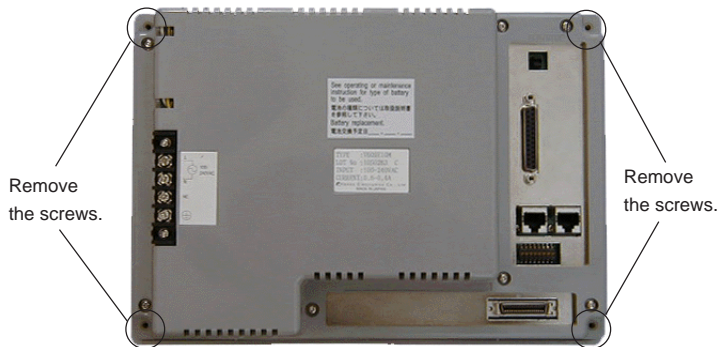

**Place it on a cloth, etc. to protect the display panel from scratches.**

2. Remove the rear external case softly according to the following direction to show the internal PC board.

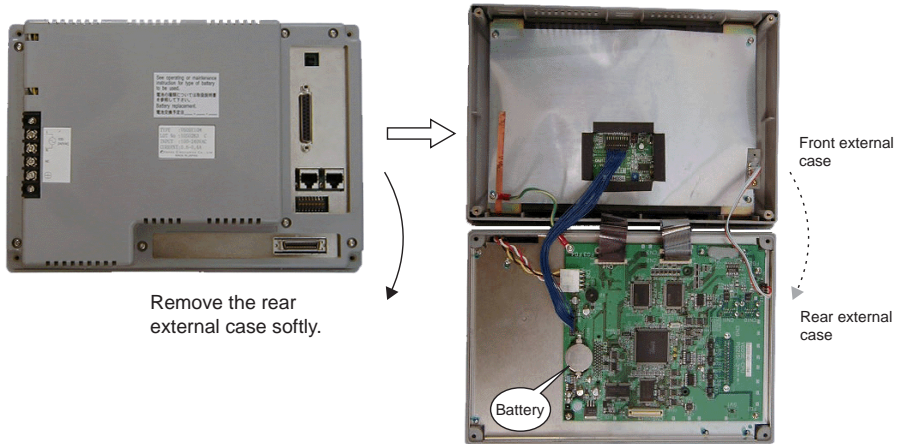

**Do not remove the cables connecting the front case to the rear case.**

**Doing so may result in failure.**

3. Disconnect the battery from the connector.

Remove the battery at the side of  $\ominus$  in the battery connector by pressing it in the direction of the  $\oplus$  side.

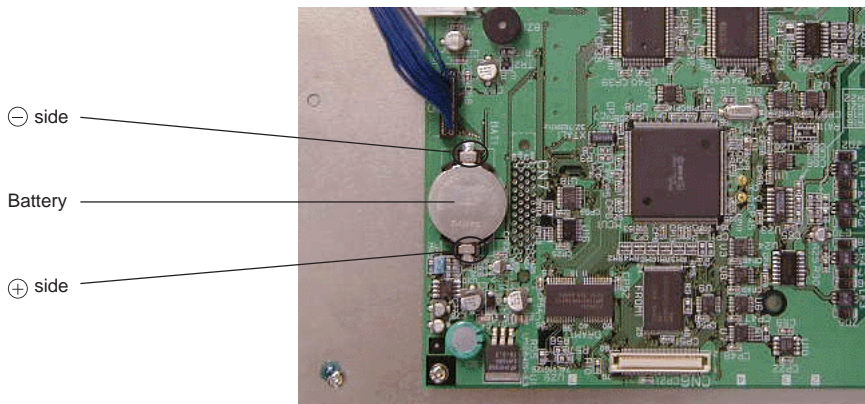

4. Replace it with a new one.

Set the battery with the  $\oplus$  side upward. When setting the battery, put it at the side of  $\oplus$ , and then, put it in the  $\ominus$  side by pressing it in the direction of the  $\oplus$  side.

5. Close the rear case of V609E.

6. Attach the 4 external screws.

7. Remove the caution seal from V609E.

Write down the date after 5 years in the section of the replacement date of the caution seal, and put up the seal on the rear of V609E.

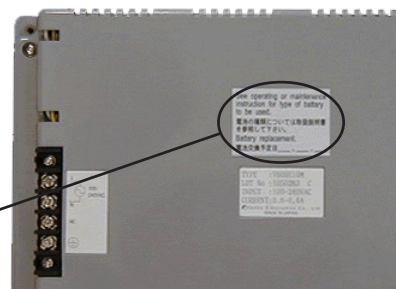

8. Turn on V609E.

Transfer the RAM file in the case of saving it before the replacement.

# MEMO

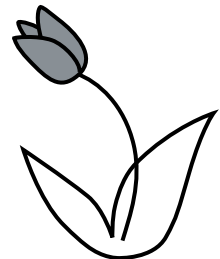

Please use this page freely.



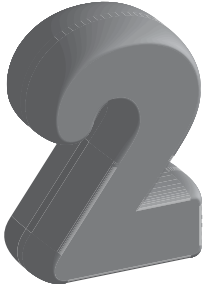

# System Menu

---

1. Operation of Main Menu
2. Errors Caused on the V609E



# 1 Operation of Main Menu

When the power of V6 is turned on for the first time, the screen on the below left is displayed. After transferring the screen data to V6, the following "Main Menu" is displayed.

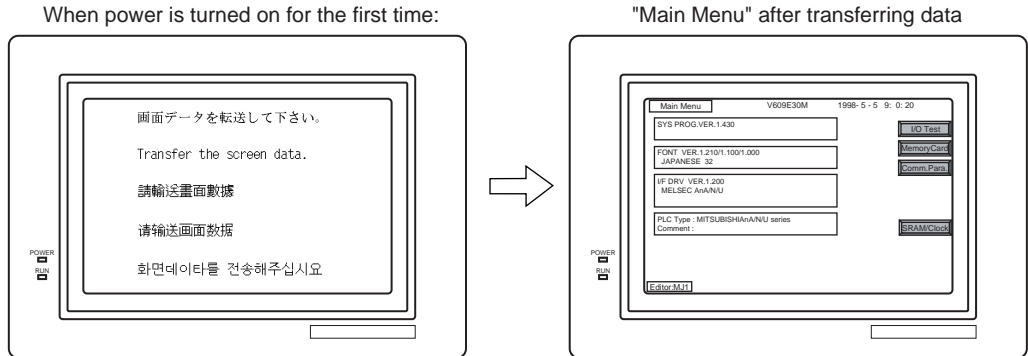

If the screen data has been already transferred to V6, press the [RUN/STOP] switch on the rear side. The [Main Menu] is displayed.

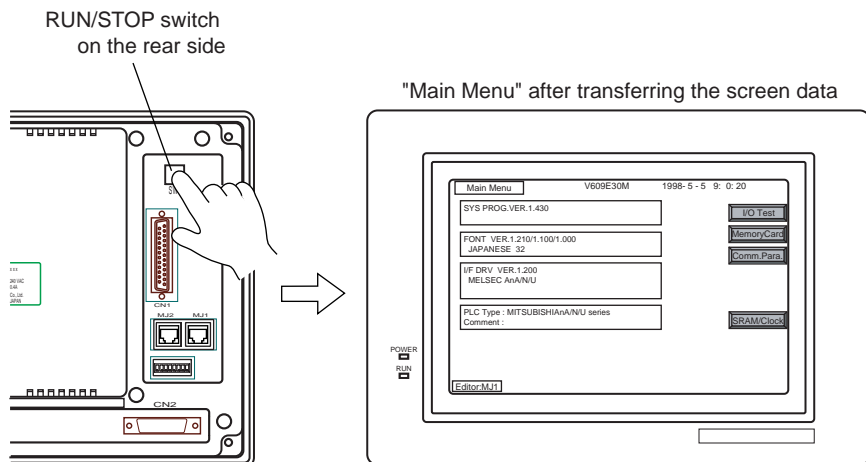

### Main Menu

The "Main Menu" is the system menu for transferring the data between a personal computer and V6. When the screen data is transferred from a personal computer to V6, the "Main Menu" or "Comm. Parameter" (see page 2-10) must be displayed.

(If [Editor port] is selected for [Modular Jack 1] in the [Modular] of the editing software, it is not necessary to display the "Main Menu.")

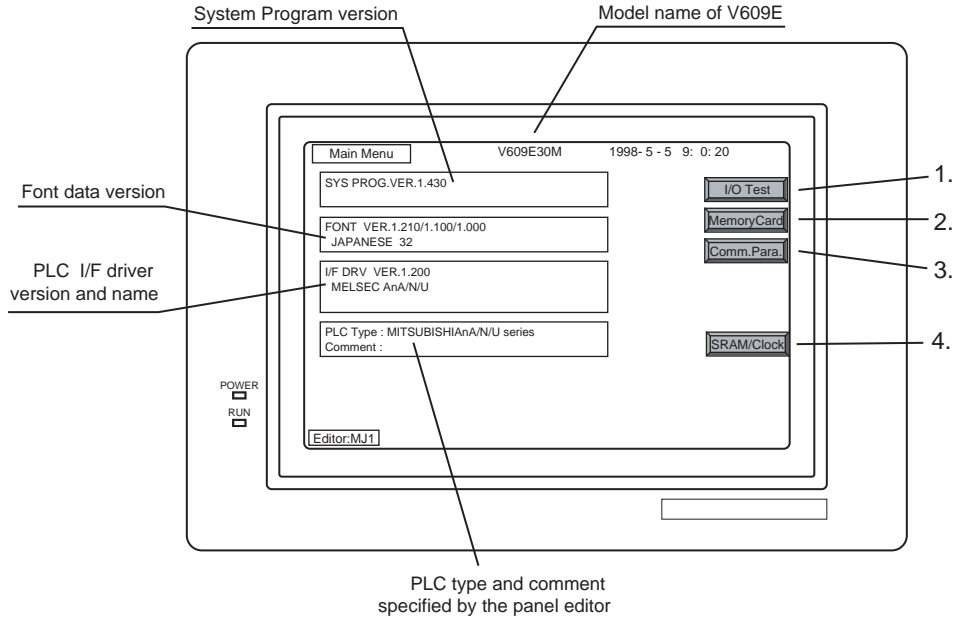

### I/O Test

When the switch '1.' on the "Main Menu" is pressed, the following "I/O Test" is displayed. This is the test menu to check only V609E hardware.

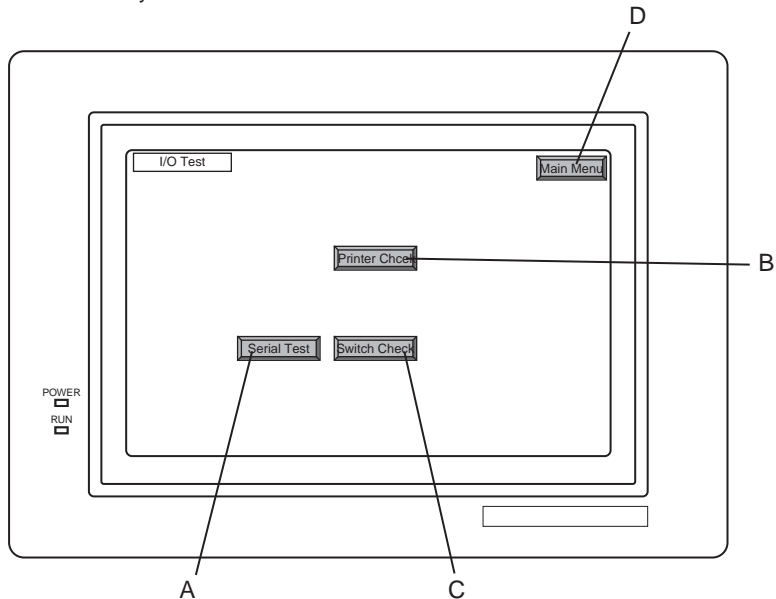

### A. Self-loop Test

Pressing the switch 'A' on the "I/O Test" brings to the [Serial Test] screen.

This is the test menu to check the signals necessary for V6 to communicate with PLC or a personal computer by using only V6.

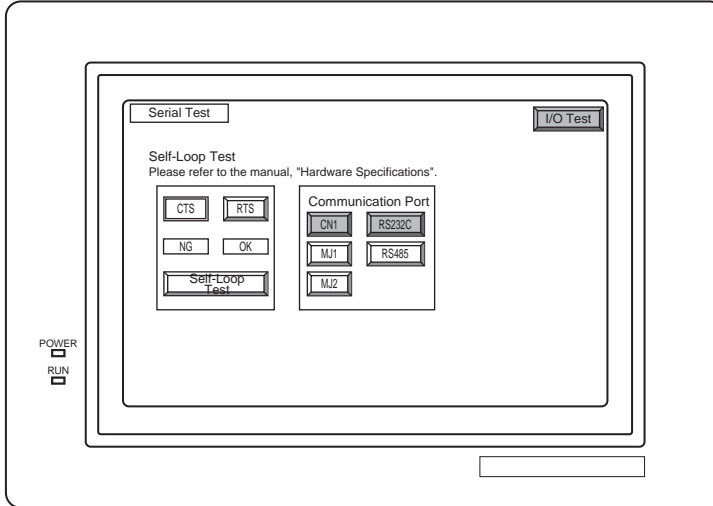

◇ Signal Test of RS-232C in CN1

Select [CN1] and [RS-232C] in [Communication Port] by pressing each switch.

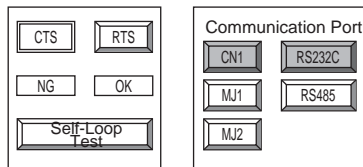

◆ Loop-back Test

Check the [SD] and [RD] signals.

1. Jump pins, 2 and 3 of CN1.
2. The test is OK, if the [OK] lamp turns on when the [Self-Loop Test] switch is pressed.

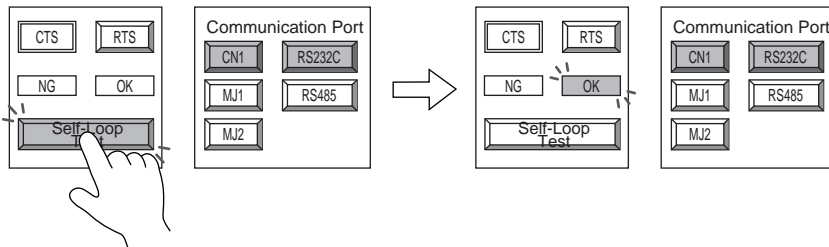

\* If the [NG] lamp turns on when the same switch as above is pressed, ask the advice of your distributor.

### ◆ Test of CTS/RTS

Check the [CTS] and [RTS] signals.

1. Jump pins, 4(RTS) and 5(CTS) of CN1.
2. The test is OK if the [CTS] lamp and the [RTS] lamp turn on at the same time that the [RTS] switch is pressed. Similarly, the test is OK if the [CTS] turns off at the same time that the [RTS] is turned off.

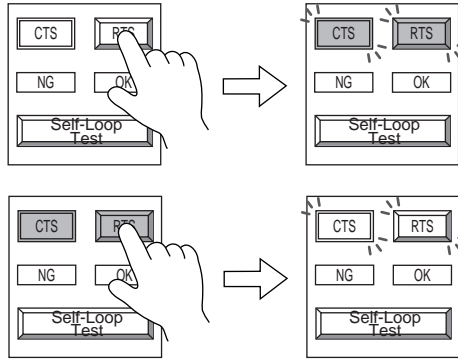

### ◇ Signal Test of RS-485 in CN1

Select [CN1] and [RS-485] in [Communication Port] by pressing each switch.

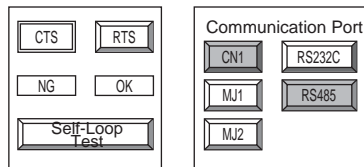

### ◆ Loop-back Test

Check the [SD] and [RD] signals.

1. Jump each pin, 12 and 24, 13 and 25 of CN1.
2. The test is OK, if the [OK] lamp turns on when the [Self-Loop Test] switch is pressed.

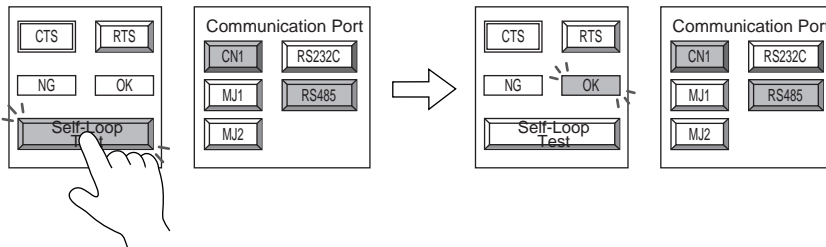

\* If the [NG] lamp turns on when the same switch as above is pressed, ask the advice of your distributor.

◆ Test of CTS/RTS

Check the [CTS] and [RTS] signals.

1. Jump each pin, 14(+RTS) and 19(+CTS), 17(-RTS) and 18(-CTS) of CN1.
2. The test is OK if the [CTS] lamp and the [RTS] lamp turn on at the same time that the [RTS] switch is pressed. Similarly, the test is OK if the [CTS] turns off at the same time that the [RTS] is turned off.

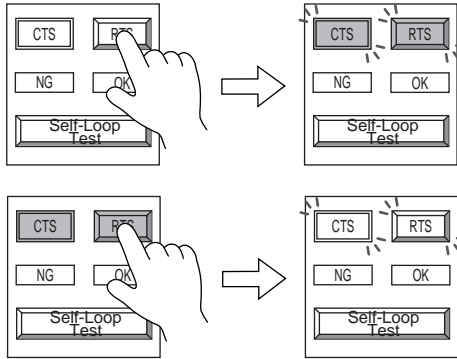

◇ Signal Test of RS-232C in MJ1 and MJ2

Select [MJ1] (or [MJ2]) and [RS-232C] in [Communication Port] by pressing each switch.

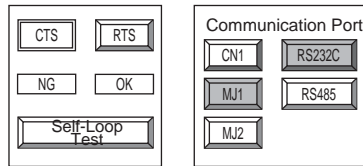

◆ Loop-back Test

Check the [SD] and [RD] signals.

Execute the test by connecting the data transfer cable (V6-CP) to CN1.

1. Set the adaptor, ADP25-9, which is attached to V6-CP, to V6-CP. And connect the modular jack side of V6-CP to MJ1 (or MJ2), ADP25-9 side of V6-CP to CN1.

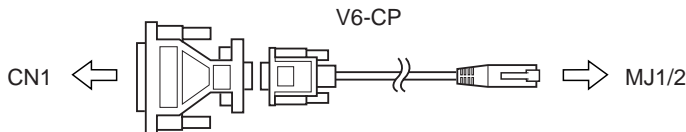

2. The test is OK, if the [OK] lamp turns on when the [Self-Loop Test] switch is pressed.

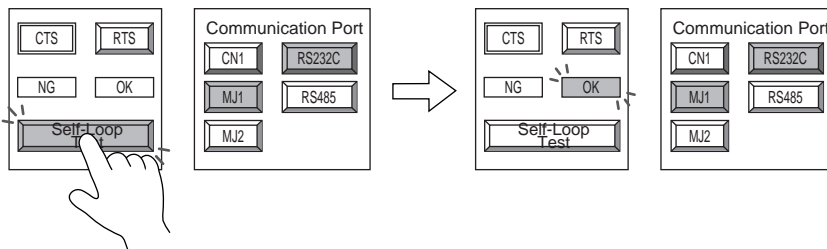

\* If the [NG] lamp turns on when the same switch as above is pressed, ask the advice of your distributor.

◇ Signal Test of RS-485 in MJ1 and MJ2

When you execute the signal test of RS-485 in MJ1 and MJ2, ask the advice of your distributor.

## B. Printer Check

Check the signal of printer.

The test is OK if the test printout is executed satisfactorily when connecting V609E to a printer and pressing this [Printer Check] switch (B).

```

!#$%&@ 0123456789 ABCDEFGHIJKLMNO
!#$%&@ 0123456789 ABCDEFGHIJKLMNO
!#$%&@ 0123456789 ABCDEFGHIJKLMNO
!#$%&@ 0123456789 ABCDEFGHIJKLMNO
!#$%&@ 0123456789 ABCDEFGHIJKLMNO
!#$%&@ 0123456789 ABCDEFGHIJKLMNO
!#$%&@ 0123456789 ABCDEFGHIJKLMNO
!#$%&@ 0123456789 ABCDEFGHIJKLMNO
!#$%&@ 0123456789 ABCDEFGHIJKLMNO
!#$%&@ 0123456789 ABCDEFGHIJKLMNO

```

## C. Switch Check

Check the reaction of the touch switches on the V609E panel.

When the [Switch Check] switch (C) is pressed, the following screen is displayed.

Confirm that the color of the pressed area changes into orange-yellow.

The orange-yellow color means that the switch reacts to the touch normally.

Pressing the corner right below [\*] leads to the previous [I/O Test] screen.

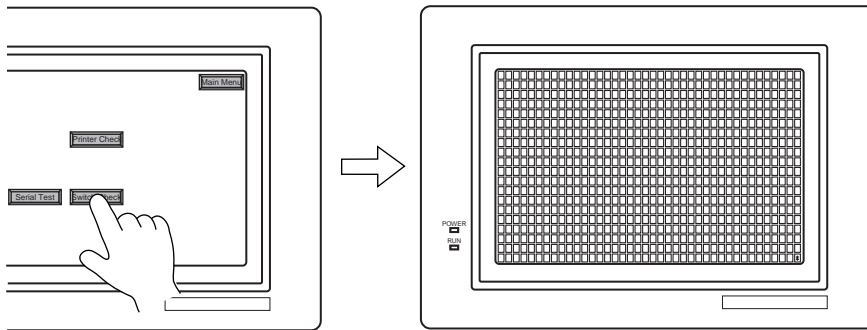

If the pressed area is reversed, these switches reacts to the touch normally.

## D. Main Menu

Pressing this [Main Menu] switch (D) leads to the previous [Main Menu].

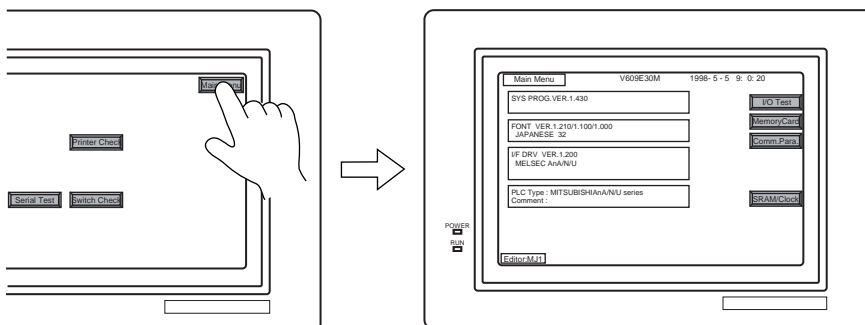



## Memory-Card

When the [Memory-Card] switch (2.) on the "Main Menu" is pressed, the following "Memory-Card" is displayed.

This screen is to transfer the screen data between V609E and a memory-card.

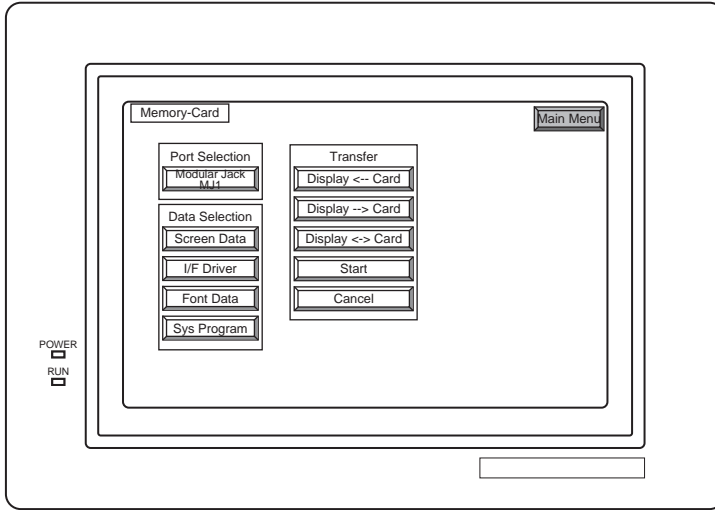

### ◆ Procedure of Data Transferring

#### 1) Port Selection

Select the [Modular Jack MJ1] switch (or [Modular Jack MJ2]) in case of using a modular jack.

When each switch is pressed, the "Memory-Card Information" window is displayed.

Pressing the "Close" switch leads to the original screen after checking the memory card information.

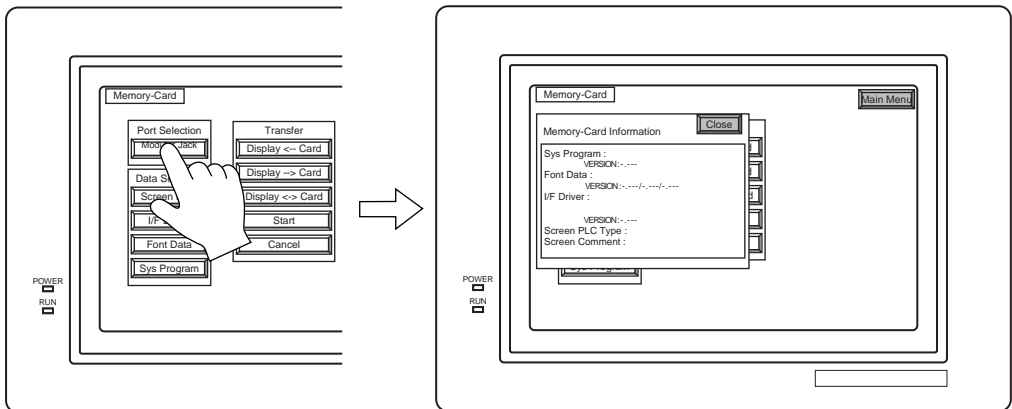

\* In case of selecting [Card Recorder] from [Modular Jack 2] on V-SFT and transferring data, it is possible to select the [Modular Jack 2] switch in the [Port Selection] menu of the [Memory-Card] screen on V6.

2) Data Selection, Transfer

Pressing each switch leads to selection of the target for data transferring. (Possible to select multiple items.)

Data Selection

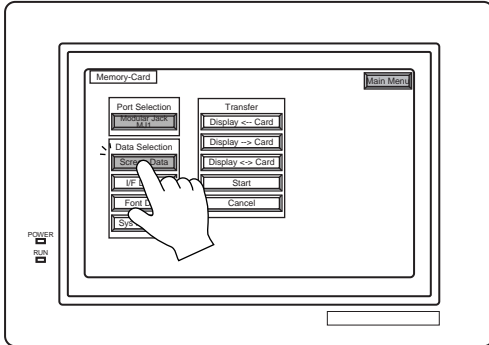

Transfer

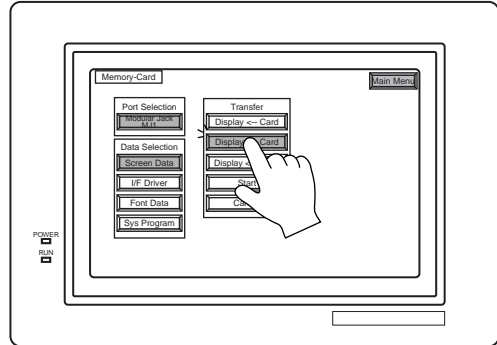

3) Start

When the [Start] switch is pressed, the data transferring starts. During data transfer, the character, the lamp of 'Start' switch is turned ON.

After transferring data, the following message is displayed. Press the [OK] switch.

Start transferring

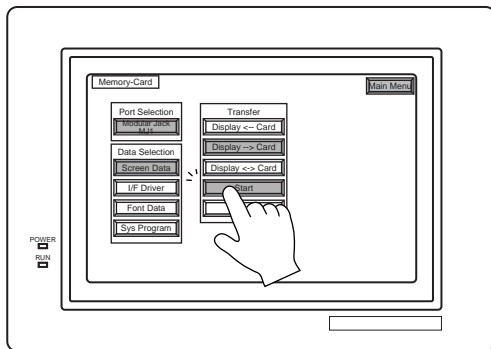

During transferring

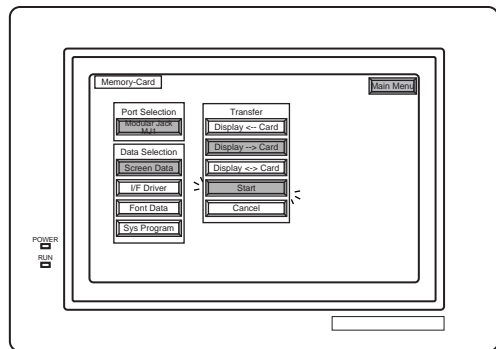

Finish transferring

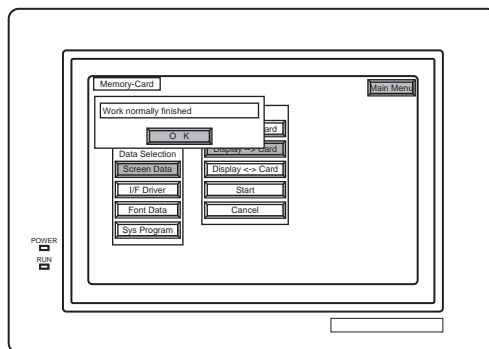

## ◆ Message Display in Data Transferring

If an error occurs during transferring data, the message display window shown on the right is displayed. The kinds and the contents of the messages are as shown below.

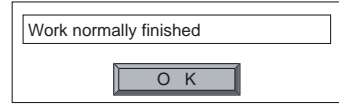

Message	Contents
Work normally finished.	The specified operation has been concluded normally.
CREC not connecting	CREC is not connecting when selecting a modular jack.
CREC Communication Error	A communication error occurred between V6 and CREC when selecting a modular jack.
Memory-Card not setting	A memory card is not inserted.
Memory-Card Capacity over	Cannot write the data into a memory card because the data size in V6 is larger than the capacity of a memory card.
Write Protect : ON	Cannot write data into a memory card because the write protect switch in a memory card is ON.
Writing Error occurred.	The error occurred while writing data into a memory card.
Selected data does not exist.	The data in the reading target does not exist.
V6 type is different.	The specified type of the data in V6 is different from the type of the memory card data.
Selected data can not be read.	The data in a memory card cannot be read.
Reading Error occurred.	The error occurred during writing data into a flash ROM of V6.
Data discrepant	There is some discrepancy in data, when comparing data between a memory card and V6.
Screen data on V6 will be broken.	This message appears to inform the user that the data in V6 will be broken by transferring the font data (the size which is larger than the present data) from a memory card to V6. (The [OK] switch continues the transferring. The [Cancel] switch stops transferring.)
Undefined Error occurred.	The error occurred due to some cause other than the above mentioned.

## Comm. Para.

When the [Comm. Para.] switch (3.) on the "Main Menu" is pressed, the following "Comm. Param." is displayed.

This screen is to show the setting of communication parameter of V609E.

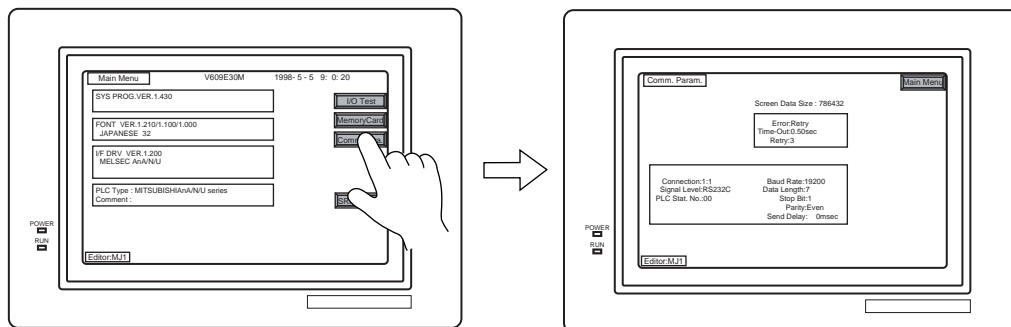

## SRAM/Clock

When the [SRAM/Clock] switch (4.) on the "Main Menu" is pressed, the following "SRAM/Clock Adjustment" screen is displayed.

This screen is to adjust the V609E built-in clock, and format the SRAM area.

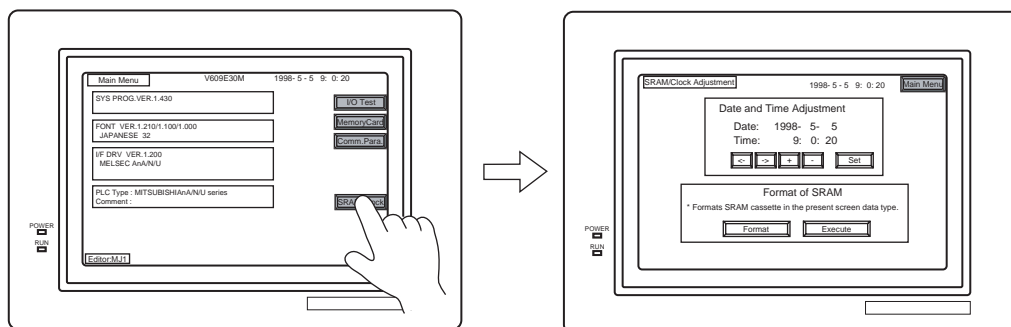

### ◆ Data and Time Adjustment

- 1) Move the cursor by using [→] or [←] switch, and then use [+] or [-] switch to adjust both date and time.
- 2) Press the [Set] switch after adjusting both date and time.
- 3) Both of them are displayed in the time display located above.

### ◆ Format of SRAM

Format of SRAM makes the data which is currently stored in the SRAM erased. Whenever you try to format the SRAM area, take note about this and perform the format carefully.

- 1) First, press the [Format] switch, and then do the [Execute] switch.  
The format of SRAM is performed in the present screen data type.
- 2) The [**\*\* Format Completed \*\***] message appears after the format of SRAM is performed successfully.

# 2 Errors Caused on the V609E

## Communication Error

The followings are the errors which are often caused on the V6 series.

About any other errors except these errors, refer to 'Appendix 3 Error' in "Reference Manual (Function)."

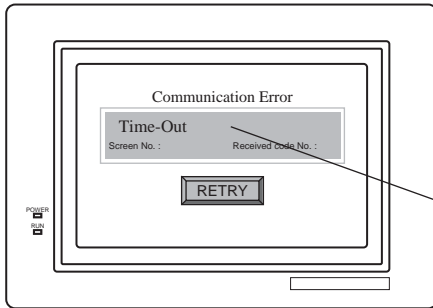

\* When you go to [Comm. Parameter], bring up the [Detail] tab window and set [Continuous] for [Comm. Err. Handling], a screen like the one shown below is displayed.

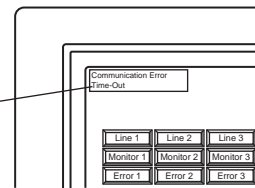

This portion of the message changes.

Message	Contents	Solution	Remarks
Time-Out *	Although a request is sent for transmission to the PLC, an answer is not returned within the required amount of time.	1) Check the communication parameter. 2) Check the cable and wiring. 3) Data may be disrupted because of noise. Fix noise.	A B
Error code received	An error code was sent to the link unit by the CPU of the PLC.	Solve the problem by examining the CPU error code.	
Check I/F driver (applicable to I/F driver for Simulator)	When sending a communication request to a personal computer (simulator), there is no reply from a personal computer.	If a simulator is not used, transfer the I/F driver for PLC again.	

\* If the above error messages are displayed on the V609E without establishing communication between V609E and PLC, test the solution of remark "A."  
If the error occurs suddenly in communication, test the solution of remark "B."

## System Error

When a system error is detected, the following error screen is displayed.

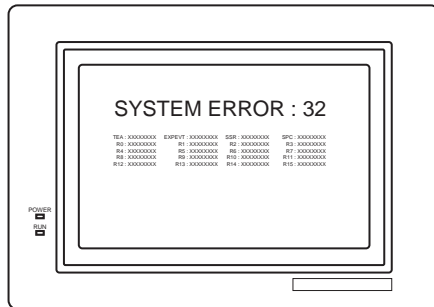

Error : XX

- |    |   |
|----|---|
| 1  | : Watch dock timer error  |
| 11 | : Switch table error  |
| 30 | : Request for displaying full error   |
| 31 | : Memory allocation system error  |
| 32 | : General exceptions/MMU address system error   |
| 33 | : RTOS system error   |
| 34 | : Memory error  |
|    | (when detecting an error by self-check of RAM)  |
| 35 | : Inaccurate memory error   |
|    | (when detecting an access to a memory of an inaccurate memory model,<br>e.g. PLC or internal memory etc.) |

The source of the error could be one of the following three problems. Contact the technical support department of your distributor.

- 1) Program crash due to noise
- 2) Hardware problem
- 3) Bad program

## Others

About any other errors except one in this chapter, refer to 'Appendix 3 Error' in "Reference Manual (Function)."

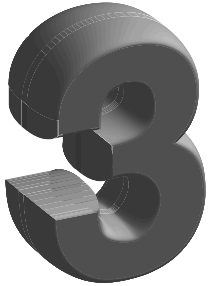

# Editing & Converting Screen

---

1. Screen Editing of V609E
2. GD-80E -> V609E Conversion





# 1 Screen Editing of V609E

V609E is developed as a higher-level model that replaces GD-80E (Monitouch GD series of EL display type).

**Concerning the items to be taken into consideration when converting the GD-80E data to V609E screen data, refer to “2 GD-80E --> V609E Conversion.”**

The following describes the procedure for newly creating the screens using V609E.

## Setting Procedure

A new V609E screen will be created according to the following procedure.

1. Start V-SFT, and click the [New] icon, or select [New] from the [File] menu.

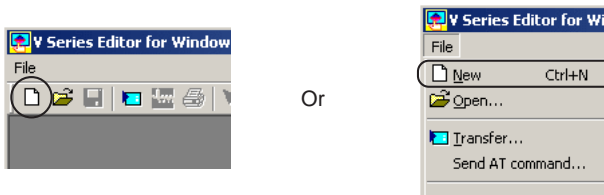

2. The [Edit Model] dialog is displayed.  
Select [V609E (640\*400 8.9 inches)], then click [OK].

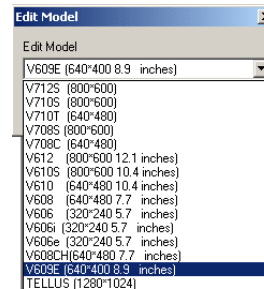

3. The [Select PLC Type] dialog is displayed. Select a PLC model, then click [OK].  
According to the selected PLC model, the [Comm. Parameter] dialog may be displayed. After checking the setting, click [OK].

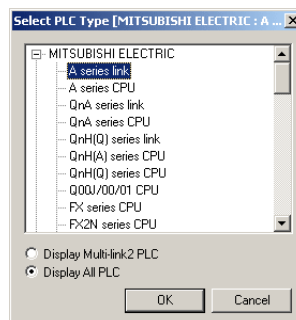

4. The [Screen [0] Edit] window is displayed. Start screen editing.

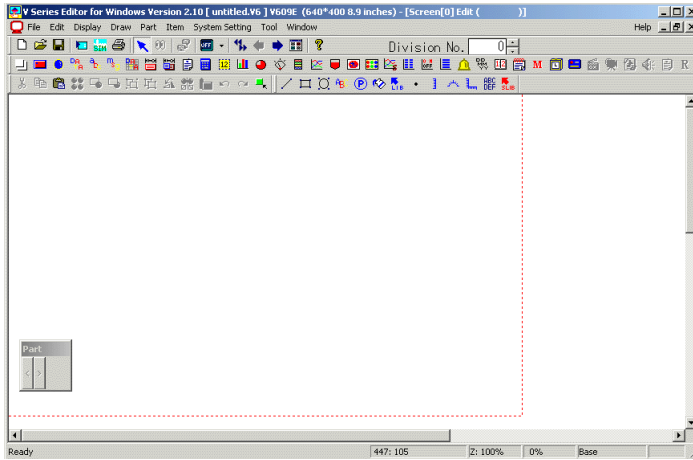

### Restrictions on Creating New Screens with V609E

When creating a screen newly using V609E, restrictions indicated below should be taken into consideration.

#### ◆ Screen memory

About 760k bytes (could increase according to the font to be used)  
Expansion of memory size is not allowed.

#### ◆ Overlap size

Although up to 3 overlaps can be displayed simultaneously on a screen, data size for overlapping is limited.

Total data size of overlaps is 256,000 bytes.

Example 1) Creating a single overlap

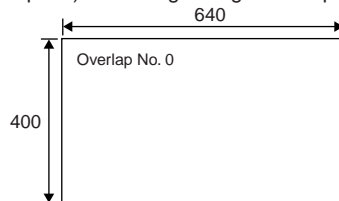

$$640 \times 400 = 256,000 \leq 256,000$$

\* Displaying other overlaps is not possible.

Example 2) Creating two overlaps

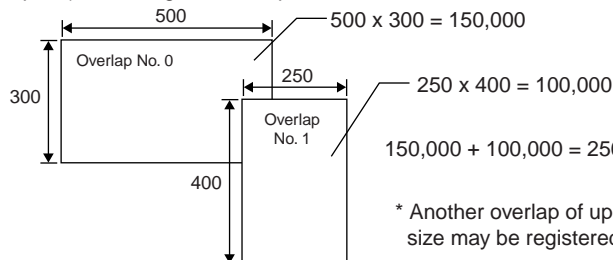

$$500 \times 300 = 150,000$$

$$250 \times 400 = 100,000$$

$$150,000 + 100,000 = 250,000 \leq 256,000$$

\* Another overlap of up to 6,000-byte size may be registered.

\* When a total data size of overlaps displayed in one screen exceeds the limit indicated above, error message "Data has some error Error:54" is displayed in V609E and communication with a PLC is disabled. Always observe the limit of the data size when creating overlaps.

◆ Display colors

V609E has only two colors - black and orange yellow.

The relationship between the color setting at the editor and displayed color on V609E is indicated in the table below.

Software setting	V-SFT (Default)		V-SFT Setting of [Display: Reversed image] ([Unit Setting] --> [Backlight])	
	Black	Other than black	Black	Other than black
Hardware	Black	Orange yellow	Orange yellow	Black

Create a screen taking the relationship above into consideration.

- \* It is possible to check the display image using the screen editor.
- Select [Display Environment] from the [Display] menu.
- In the [Display Environment] dialog, click the [Others] tab window.
- Check the [Monochrome 8-grade Display] and click [OK].

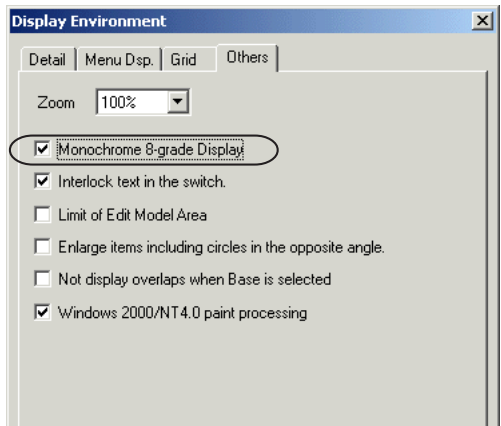

Display colors on the screen are set as shown below with the setting above.

Software	[Display Environment]	V-SFT (Default)		V-SFT Setting of [Display: Reversed image] ([Unit Setting] --> [Backlight])	
	<input type="checkbox"/> Monochrome 8-grade Display]	Black	Other than black	Black	Other than black
	<input checked="" type="checkbox"/> Monochrome 8-grade Display]	Black	White	Black	White
Hardware	V609E	Black	Orange yellow	Orange yellow	Black

# 2 GD-80E -> V609E Conversion

## CONSIDERATIONS ON HARDWARE

When you replace GD-80E with V609E, note the following points.

Item	Model	GD-80EH/E0	V609E	Countermeasures
Effective display area		8.9"	8.9"	—
Panel cutout dimensions		277 W x192 H mm	277 W x192 H mm	—
Display device		GD-80EH : High-intensity EL GD-80E0 : EL	High-intensity EL	Use high-intensity EL also to replace GD-80E0 (EL).
Resolution for display		640 (W) x 400 (H) dots	640 (W) x 400 (H) dots	—
Resolution for touch switches		20 (horizontal) x 10 (vertical) switches (Matrix type)	40 (horizontal) x 20 (vertical) switches (Matrix type)	—
External I/O terminals		With RUN, STOP and BZ terminals	RUN, STOP and BZ terminals are not available.	None
RS-422 terminal		(Only for GD-80xxx0) Available	Not available	Use terminal converter TC485 or TC609 (only for V609E) (product of Hakko Electronics: both options).
D-sub 15-pin connector (For direct connection to Mitsubishi A/Q/FX CPU)		(Only for GD-80xxxM) Available	Not available Direct connection to CPU is possible using standard D-sub 25-pin connector	* To use MB-CPU (cable for D-sub 15-pin connector)  Use terminal converter TC609 + MB-CPU .  * To connect to CPU using D-sub 25-pin connector  Use D-sub 25-pin connector cable, MB-CPUQ .
Screen data transfer cable		Connected to D-sub 25-pin connector. GD-CP GD-CPV	Connected to modular jack. Accordingly, the cable prepared for GD-80 cannot be used.	Use screen data transfer cable for V6, V6-CP (product of Hakko Electronics).
Communication cable		Connected to D-sub 25-pin connector.	Connected to D-sub 25-pin connector. Accordingly, the cable prepared for GD-80 can be used.	—

Item \ Model	GD-80EH/E0	V609E	Countermeasures
Printer port	Centronics 14-pin connector Standard printer cable for PC-9801 is used.	Half-pitch 36-pin connector Accordingly, the printer cable prepared for GD-80 can not be used.	Use printer cable for V6, V6-PT (product of Hakko Electronics).
Barcode reader connection	(Only for GD-80x2x) D-sub 9-pin connector is available. Standard specification provides the connector for barcode reader.	Connected to the modular jack.	Use barcode reader cable for V6, V6-BCD (product of Hakko Electronics).
Storing screen data in memory card	Can be stored using recorder, GD-MREC01 .	GD-MREC01 can not be used.	Use card recorder for V6, CREC (product of Hakko Electronics).
Memory card function	(Only for GD-80x2x) Compatible by using recorder, GD-MREC02 .	GD-MREC02 can not be used.	Use card recorder for V6, CREC (product of Hakko Electronics).
Memory card REC-MCARD	Flash ROM	Cannot be used directly.	Store the memory card data using GD-SFT80WE then read and convert the data using V-SFT.
	SRAM	Cannot be used directly.	<p>* If the memory card was used to store the screen data backup:</p> <p>Store the memory card data using GD-SFT80WE then read and convert the data using V-SFT.</p> <p>* If the memory card function was used:</p> <p>Change the applicable model name written to the memory card using M-CARD SFT (to be purchased separately).</p>
Protective screen filter	[GD-GS80E]	[GD-GS80E]	—
Water-proof screen filter	[GD-WP80E]	[GD-WP80E] (Complies with IP64)	—

## CONSIDERATIONS ON SOFTWARE

### Converting Procedure

1. Start V-SFT, then click the [Open] icon, or select [Open] from the [File] menu.



2. The [Open a screen data file] dialog is displayed.  
Change the [Files of type] to [\*.\*80].

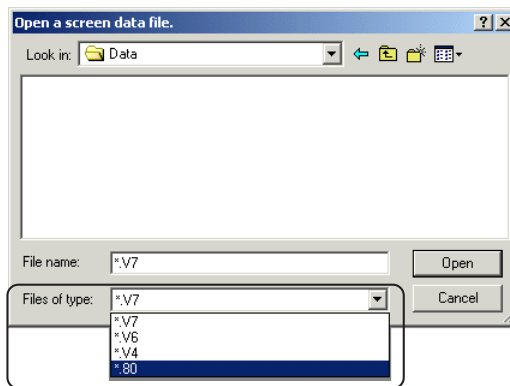

3. The GD-80 screen data files are displayed in this dialog.  
Specify the GD-80 screen data file to convert, and click [Open].

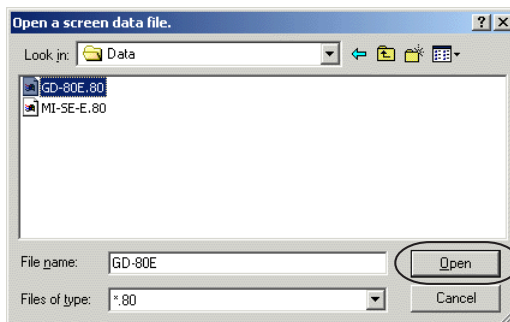

4. The [Edit Model] dialog is displayed.  
Select [V609E (640\*400 8.9 inches)], then click [OK].

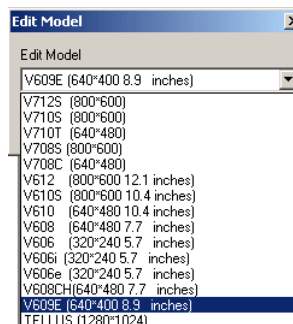

- The screen edit window is displayed.  
GD-80E screen converted for V609E is displayed.

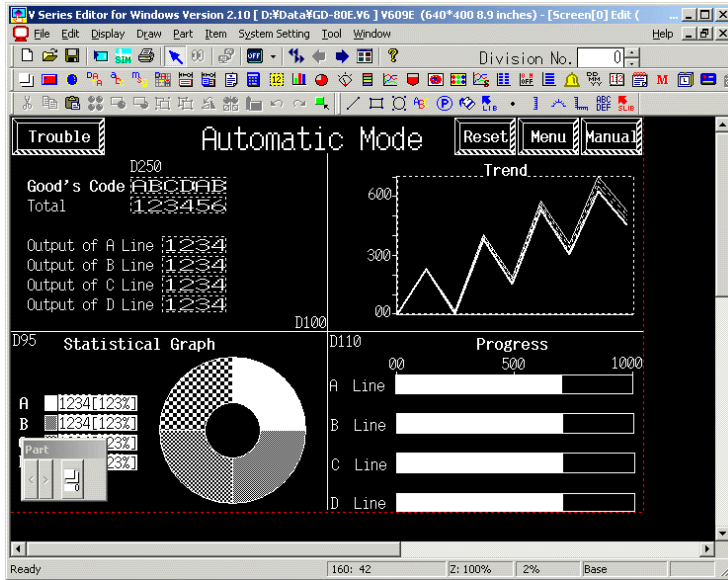

### Cautions on conversion

Conversion contents are largely classified into two categories when converting the GD-80E screen data into the data for V609E.

- ◆ Data converted as GD-80 compatible data
- ◆ Functions that cannot be converted as GD-80 compatible data (as of V-SFT Ver. 2.2.0.0)





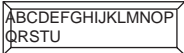
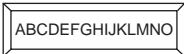

Described below are cautionary items to be taken into consideration for each conversion content.

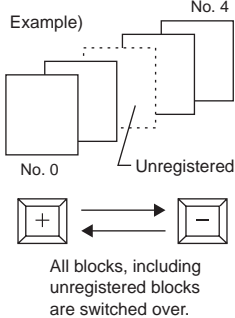
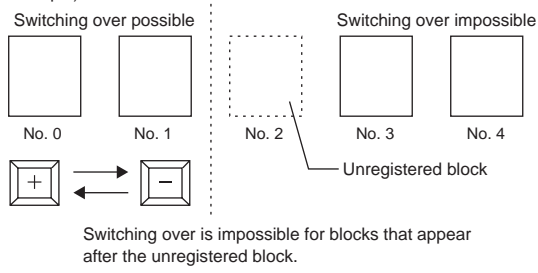
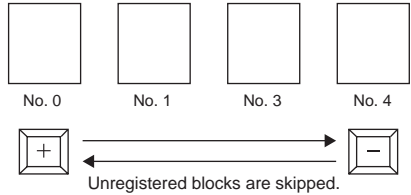
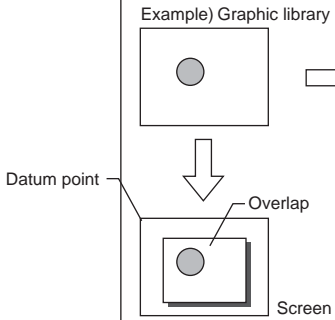
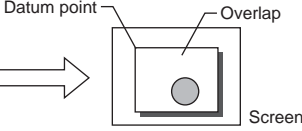
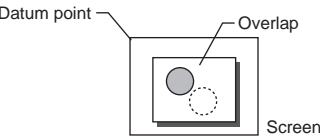
Item \ Model	GD-80E	V6
Continuous buzzer sound	The buzzer keeps sounding while read area n, bit 10 is ON.	<u>Possible</u> By checking [Use continuous buzzer sound] in the [Environment Setting] tab window of [Unit Setting]
Overlap bit command	Overlap is displayed while read area "n+1", bit 12 is ON. (The overlap is kept displayed even if the display is changed.)	<u>Possible</u> By checking [Display an overlap be level of ON bit] in the [Environment Setting] tab window of [Unit Setting]  With check mark : Same operation as GD-80. Without check mark : Bit 12 setting is recognized at the signal edge.  (Even if the bit is set ON, the overlap is cleared when the display is changed.)
Character entry mode	Continuous entry of characters is permitted even after pressing the [ENT] key.	<u>Possible</u> By checking [Clear characters when cursor is on the 1st character in Entry Mode] in the [Environment Setting] tab window of [Unit Setting]
Calendar display	Message representing day of week is registered in message edit	<u>Possible</u> Calendar is converted as [Calendar parts] and the message in the message edit is automatically copied to and registered in the [Week] tab window in the calendar parts.

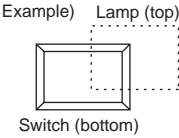
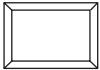
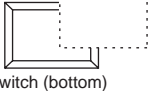
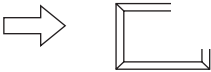
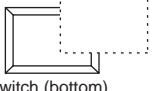
Item \ Model	GD-80E	V6																
Bar code reader	[Read Data] to be entered in the memory address set for [I/F Memory] of [Bar Code Setting] is "word units."	<p>Possible</p> <p>By checking [Output the number of data read by a bar-code reader by words] in the [Environment Setting] tab window of [Unit Setting]</p> <p>With check mark : Same display as GD-80. Without check mark : To be output in byte units.</p>																
Relay mode / Page mode / Direct mode ([Action: Switch/ Lamp])	<p>If a message overflows the switch/lamp area, overflowing characters are not displayed.</p> <p>Example) Switch</p>  <p>Actually, characters "P...U" continue after "O."</p>	<p>&lt;Previous Version&gt;</p> <p>If a message overflows the switch/lamp area, overflowing characters are continuously displayed in the second line.</p> <p>On V6</p>  <p>Message is displayed in multiple lines.</p> <p>&lt;V1.2.19.0 or later&gt;</p> <p>Possible</p> <p>By checking [Make messages same as in GD-80 if [Action area] is [Switch/Lamp]] in the [Environment Setting] tab window of [Unit Setting]</p> 																
Numerical data display	<p>In the case of overflow, lower digits are displayed.</p> <p>Example: D100 = D1234 4-digit display: 1234 2-digit display: 34</p>	<p>Possible</p> <p>By checking [Num. Display: displays the significant figures when overflowing] in the [Environment Setting] tab window of [Unit Setting]</p> <p>With check mark : Same display mode as with GD-80. 4-digit display: 1234 2-digit display: 34</p> <p>Without check mark : Display is given in the manner shown below. 4-digit display: 1234 2-digit display: --</p>																
Numerical data display	<p>In the setting of [Code: BCD], display at the GD-80 is as shown below.</p> <table border="0"> <tr> <td>PLC side</td> <td>GD-80 side</td> </tr> <tr> <td>0 to 9</td> <td>0 to 9</td> </tr> <tr> <td>A</td> <td>.</td> </tr> <tr> <td>B</td> <td>:</td> </tr> <tr> <td>C</td> <td>-</td> </tr> <tr> <td>D</td> <td>+</td> </tr> <tr> <td>E</td> <td>(space)</td> </tr> <tr> <td>F</td> <td>(space)</td> </tr> </table>	PLC side	GD-80 side	0 to 9	0 to 9	A	.	B	:	C	-	D	+	E	(space)	F	(space)	<p>Possible</p> <p>By checking [Num. Display: displays special characters instead of A to F in BCD] in the [Environment Setting] tab window of [Unit Setting]</p> <p>With check mark : Same display mode as with GD-80. Without check mark : "A" - "F" are always displayed in "0."</p>
PLC side	GD-80 side																	
0 to 9	0 to 9																	
A	.																	
B	:																	
C	-																	
D	+																	
E	(space)																	
F	(space)																	

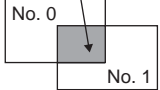
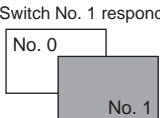

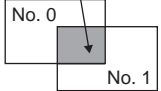
Item / Model	GD-80E	V6
<p>Switching over of numeric data blocks (Numeric key mode, [Action: Plus block/Minus block] switch)</p>	<p>Switching over is processed even when unregistered numeric data blocks exist between [Start No.] and [End No.] of switching over target [Block No.].</p> <p>Example)</p>  <p>All blocks, including unregistered blocks are switched over.</p>	<p>&lt;Previous Version&gt; If an unregistered numeric data block exists within switching over target block range specified by [Start No.] and [End No.], block switching over processing is suspended at an unregistered block.</p> <p>Example)</p>  <p>Switching over is impossible for blocks that appear after the unregistered block.</p> <p>&lt;V1.2.19.0 or later&gt; <u>Possible</u> By checking [Skip tenkey block which doesn't exist when operating +/- block switch] in the [Environment Setting] tab window of [Unit Setting]</p>  <p>Unregistered blocks are skipped.</p>
<p>Graphic relay mode on overlap</p>	<p>When a graphic relay is set on an overlap, the registered graphic is displayed in reference to the datum point of the screen.</p> <p>Example) Graphic library</p> 	<p>&lt;Previous Version&gt; For the display of the graphic relay on an overlap, the registered graphic is displayed in reference to the datum point of the overlap.</p>  <p>&lt;V1.2.19.0 or later&gt; <u>Possible</u> By checking [Regard the origin of graphic relay on an overlap as that of a screen] in the [Environment Setting] tab window of [Unit Setting]</p> 

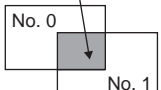
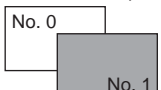
Item / Model	GD-80E	V6
<p><b>Switches/Lamps</b></p> <p>When a switch/lamp having the same OFF color as the background color is set, the objective displayed in the OFF color is invisible.</p> <p>Example) Lamp (top)              Switch (bottom)</p> <p>On GD-80 ↓</p>  At OFF, the lamp is invisible.		<p>&lt;Previous Version&gt;            On the editor or MONITOUCH, display is always given in the state the switch/lamp set on top overwrites the one set at bottom.</p> <p>Example) Lamp (top)              Switch (bottom)</p> <p>On V6 →</p>  Lamp overwrites switch. <p>&lt;V1.2.19.0 or later&gt;  <b>Possible</b>            By checking [Not paint when switch/lamp OFF color is the same as back color] in the [Environment Setting] tab window of [Unit Setting]</p> <p>Although overwriting occurs on the editor as the previous version, display on V6 is given in the same manner as GD-80.</p> <p>Lamp (top)              Switch (bottom)</p> <p>On V6 →</p>  At OFF, the lamp is invisible.
<p><b>Switches</b></p> <p>In the state two switches overlap with each other, the switch assigned a larger number (or a larger DIV No.) responds when the switch overlapping area is pressed.</p> <p>If you press this area,  </p> <p>On GD-80 ↓</p> <p>Switch No. 1 responds.  </p>		<p>After the conversion, the switch assigned a larger number (or a larger DIV No.) comes top over the one assigned a smaller number (or a smaller DIV No.) on the editor.</p>  <p>&lt;Previous Version&gt;            Pressing the overlapping area causes the switch set bottom to respond.</p> <p>If you press this area,  </p> <p>On V6 →</p> <p>Switch No. 0 responds.  </p> <p>&lt;V1.2.19.0 or later&gt;  <b>Possible</b>            By checking [Make the upward switch effective when switches are overlapped] in the [Environment Setting] tab window of [Unit Setting]</p> <p>If you press this area,  </p> <p>On V6 →</p> <p>Switch No. 1 responds.  </p>

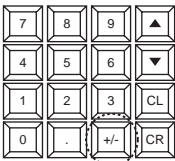
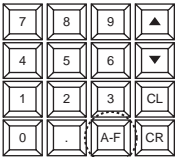
Item \ Model	GD-80E	V6
<p>Character 1 / Character 2</p>	<p>Usage differs between Character 1 display and Character 2 display.</p> <p>&lt;Character 1 display&gt;</p> <ul style="list-style-type: none"> <li>• 1-byte characters and 2-byte characters are distinguished.</li> <li>• For 1-byte characters, NULL code is processed as indicated below.</li> </ul> <p>(In LSB -&gt; MSB)</p> <p>D100 = H0041 D101 = H4443</p> <div style="border: 1px solid black; padding: 2px; display: inline-block;">A_CD</div> <small>H 41 00 43 44</small> <p>D100 = H4200 D101 = H4443</p> <div style="border: 1px solid black; padding: 2px; display: inline-block;">_BCD</div> <small>H 00 42 43 44</small> <ul style="list-style-type: none"> <li>• 2-byte characters are displayed in JIS code.</li> </ul>	<p>Conversion is made in [Char. Display]. Compatibility to character display on GD-80 is possible by checking [JIS/ASCII] of the [Detail] tab window.</p> <p>&lt;Character 2 display: <input type="checkbox"/> JIS/ASCII&gt;</p> <ul style="list-style-type: none"> <li>• Unlike GD-80, NULL code is processed as indicated below.</li> </ul> <div style="display: flex; align-items: center; justify-content: center;"> <div style="border: 1px solid black; padding: 2px; display: inline-block;">A_CD</div> <span style="font-size: 2em; margin: 0 10px;">→</span> <div style="border: 1px solid black; padding: 2px; display: inline-block;">A_ _ _</div> <div style="margin-left: 20px;"> <p>Character-string following 00 is not displayed.</p> </div> </div> <div style="display: flex; align-items: center; justify-content: center; margin-top: 10px;"> <div style="border: 1px solid black; padding: 2px; display: inline-block;">_ _ _ _</div> <div style="margin-left: 20px;"> <p>Character-string following 00 is not displayed.</p> </div> </div> <p>• Compatible with JIS code</p> <p>&lt;Character 1 display: <input checked="" type="checkbox"/> JIS/ASCII&gt;</p> <ul style="list-style-type: none"> <li>• In case of [<input checked="" type="radio"/> 1-byte] <u>Same display as GD-80</u> Same NULL code processing</li> <li>• In case of [<input checked="" type="radio"/> 2-byte] <u>Display 2-byte characters in the same JIS code as GD-80</u></li> </ul>
<p>Switching the numeric keypad to HEX data entry keys</p>	<p>The [-/+ ] key in the numeric keypad is automatically changed to the HEX entry selection key.</p> <p>Example)</p>  <p>For HEX entry ↓</p>  <p>Changed to the HEX entry selection key.</p>	<p>&lt;Previous Version&gt;</p> <p>The [-/+ ] key in the numeric keypad is not changed to the HEX entry selection key automatically. It is necessary to set the HEX entry selection key ([Function: Graphic Library]) for the individual appearances.</p> <p>&lt;V1.2.19.0 or later&gt;</p> <p><u>Possible</u></p> <p>The [Change GD80 Compatible HEX Key] item is added to [Function].</p> <p>Identical operation as with GD-80 (as shown in the left)</p>

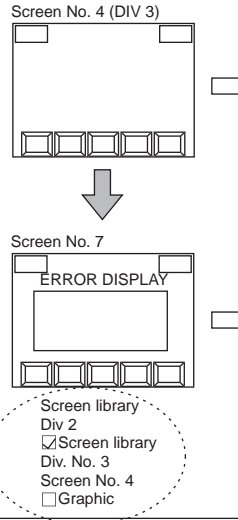
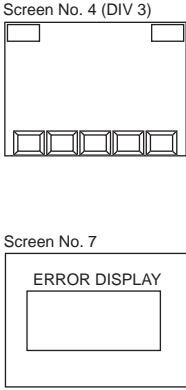
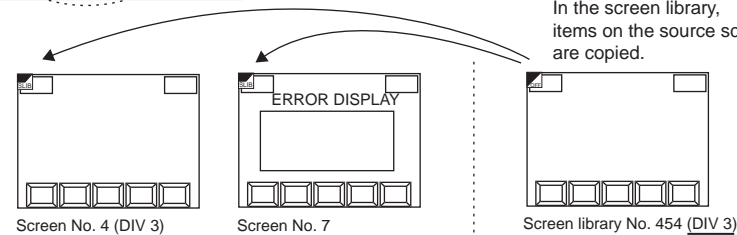
Item \ Model	GD-80E	V6																																								
Data sampling	<p>The count data is displayed in the leftmost column.</p> <table border="1" data-bbox="377 369 600 504"> <tr><td>000</td><td>55</td><td>113</td><td>3345</td></tr> <tr><td>001</td><td>64</td><td>119</td><td>3450</td></tr> <tr><td>002</td><td>33</td><td>106</td><td>3250</td></tr> <tr><td>003</td><td>48</td><td>121</td><td>2956</td></tr> <tr><td>004</td><td>56</td><td>107</td><td>2246</td></tr> </table>	000	55	113	3345	001	64	119	3450	002	33	106	3250	003	48	121	2956	004	56	107	2246	<p>&lt;Previous Version&gt; The count data is not displayed, but the leftmost column is left blank.</p> <table border="1" data-bbox="694 369 917 504"> <tr><td></td><td>55</td><td>113</td><td>3345</td></tr> <tr><td></td><td>64</td><td>119</td><td>3450</td></tr> <tr><td></td><td>33</td><td>106</td><td>3250</td></tr> <tr><td></td><td>48</td><td>121</td><td>2956</td></tr> <tr><td></td><td>56</td><td>107</td><td>2246</td></tr> </table> <p>&lt;V1.2.19.0 or later&gt; <u>Possible</u> By converting data [No. 15] on [Sampling Display Area] automatically to count display area. [Sample Count] item is added to the [Data [15]] dialog.</p> <p><b>* The count position setting [C], necessary for printing the sampling data, is automatically converted to [15] for printing the count data. (In message editing)</b></p>		55	113	3345		64	119	3450		33	106	3250		48	121	2956		56	107	2246
000	55	113	3345																																							
001	64	119	3450																																							
002	33	106	3250																																							
003	48	121	2956																																							
004	56	107	2246																																							
	55	113	3345																																							
	64	119	3450																																							
	33	106	3250																																							
	48	121	2956																																							
	56	107	2246																																							
Screen library	<p>Example) Screen library is set in the following manner</p>  <p>Screen No. 4 (DIV 3)</p> <p>Screen No. 7</p> <p>Screen library Div 2 <input checked="" type="checkbox"/> Div. No. 3 <input checked="" type="checkbox"/> Screen No. 4 <input checked="" type="checkbox"/> Graphic <input type="checkbox"/></p>	<p>&lt;Previous Version&gt; Not converted as the screen library</p>  <p>&lt;V1.2.19.0 or later&gt; <u>Possible</u> Screen library is converted as shown below.</p> <p>In the screen library, items on the source screen are copied.</p>  <p>Screen No. 4 (DIV 3)</p> <p>Screen No. 7</p> <p>Screen library No. 454 (DIV 3)</p> <p>Screen calls are set on the individual screens (source screen of GD-80 and target screen).</p> <p>How to calculate the screen library No. after conversion:</p> $\begin{aligned} \text{Screen library No.} &= \text{Original screen No.} + \text{DIV No.} \times 150 \\ &= 4 + 3 \times 150 \\ &= 454 \end{aligned}$																																								

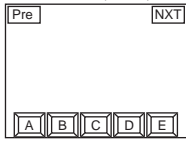
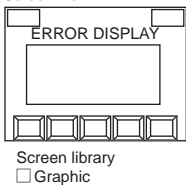
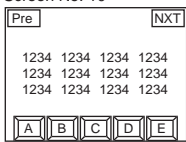
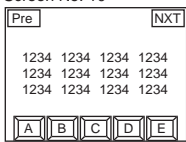
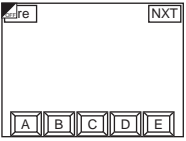
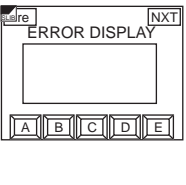
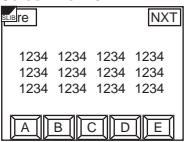
Item	Model	GD-80E	V6
<p>--&gt; Continued (Screen library)</p>	<p>If [Graphic] is checked for screen library at GD-80, the graphics is moved to screen library at V6. However, if the same screen library is used with [Graphic] checked and unchecked at GD-80, the setting for the screen assigned a larger screen number has priority.</p> <p>Example) GD-80</p> <p>Screen No. 4 (DIV 3)</p>  <p>↓</p> <p>Screen No. 7</p>  <p>.....</p> <p>Screen No. 10</p>  <p>Screen library <input type="checkbox"/> Graphic</p> <p>.....</p> <p>Screen No. 10</p>  <p>Screen library <input checked="" type="checkbox"/> Graphic</p>	<p>V6</p> <p>Screen library No. 454 (DIV 3)</p>  <p>↓</p> <p>Screen No. 7</p>  <p>.....</p> <p>Screen No. 10</p>  <p>Screen library <input checked="" type="checkbox"/> Graphic</p> <p>The status of the screen having a smaller screen number at GD-80 differs that of the screen displayed on GD-80.</p> <p>The setting at the screen having a larger screen number at GD-80 has priority.</p>	

Item \ Model	GD-80	V6
Read/Write Area	—	Possible [Main 1] tab window of [Comm. Parameter] Check [Read/Write Area GD-80 Compatible].
Background of screen	<ul style="list-style-type: none"> <li>• Screen with only background color</li> <li>• Screen with only background graphics</li> <li>• Screen with both background color and graphics</li> </ul>	<p>--&gt; Converted as unregistered screen</p> <p>--&gt; Converted as a screen with a graphic call</p> <p>--&gt; Converted as a screen with a background color and a graphic call</p>
Overlap	<ul style="list-style-type: none"> <li>• Normal No items are registered in a screen except an overlap in DIV0.</li> <li>• Other items except an overlap are registered in other DIV, or an overlap is not registered in DIV0.</li> </ul>	<p>--&gt; An overlap is registered in the same number of a multi-overlap edit as one of a screen in GD-80 automatically.</p> <p>--&gt; An overlap is registered as a normal overlap in a screen. And an overlap is also registered in the same number of a multi-overlap edit as one of a screen in GD-80 automatically.</p>
Switch/Lamp	[Frame type: graphics]	[Graphic Call] is automatically set on the screen for creating/editing switch/lamp parts.
Switch	[Switch Memory] of the following [Function]: [Normal] [Block] [+/- Block] [Mode] [Bit Operation]	--> Converted to [Output Memory].
Relay mode	<ul style="list-style-type: none"> <li>• DIV0</li> <li>• DIV1</li> <li>• DIV2</li> <li>• DIV3</li> </ul>	<p>--&gt; Converted to [Relay Info. Output] as Write Area n+5.</p> <p>--&gt; Converted to [Relay Info. Output] as Write Area n+8.</p> <p>--&gt; Converted to [Relay Info. Output] as Write Area n+11.</p> <p>--&gt; Converted to [Relay Info. Output] as Write Area n+14.</p>
Tenkey mode	—	<p>Entry mode</p> <ul style="list-style-type: none"> <li>• The contents of [Command Memory] are the same as that of GD-80.</li> <li>• Write Area n+2 is automatically specified for [Info. Output Memory].</li> <li>• Characters in a keypad [0] to [9] and [,] are converted to the drawing characters on a screen. [0] to [9] and [,] are also stored in [Char. Entry] in the [Switch] dialog in 1-byte character. The characters within the switch are placed off the screen so that they do not cover the drawing characters.</li> </ul>

Item \ Model	GD-80	V6																		
Tenkey mode	[Type: Direct]	<ul style="list-style-type: none"> <li>[Type: Direct]</li> <li>For numerical displays on a screen, [Display Function: No] is set.</li> </ul>																		
	[Type: Indirect]	<ul style="list-style-type: none"> <li>[Type: Data Display]</li> <li>[Target Memory: Output Memory]</li> <li>[Input Item Select: External]</li> <li>[GD 80 Compatible: (checked)]</li> <li>When there is no overlap, "4" is set. When there is an overlap, the DIV No. for the overlap of GD-80 is set.</li> <li>For numerical displays on a screen, [Display Function: Entry Target] is set. The number of [Order] is converted automatically as shown below.</li> </ul> <table border="1" style="margin-left: auto; margin-right: auto;"> <thead> <tr> <th colspan="2">GD-80</th> <th>V6</th> </tr> <tr> <th>DIV No.</th> <th>Data No.</th> <th>Order</th> </tr> </thead> <tbody> <tr> <td>0</td> <td>0 to 31</td> <td>0 to 31</td> </tr> <tr> <td>1</td> <td>0 to 31</td> <td>32 to 63</td> </tr> <tr> <td>2</td> <td>0 to 31</td> <td>64 to 95</td> </tr> <tr> <td>3</td> <td>0 to 31</td> <td>96 to 127</td> </tr> </tbody> </table>	GD-80		V6	DIV No.	Data No.	Order	0	0 to 31	0 to 31	1	0 to 31	32 to 63	2	0 to 31	64 to 95	3	0 to 31	96 to 127
	GD-80		V6																	
	DIV No.	Data No.	Order																	
0	0 to 31	0 to 31																		
1	0 to 31	32 to 63																		
2	0 to 31	64 to 95																		
3	0 to 31	96 to 127																		
[Type: Block]	<ul style="list-style-type: none"> <li>[Type: Block]</li> <li>[Target Memory: Output Memory]</li> <li>[Input Item Select: Internal]</li> <li>[GD 80 Compatible] cannot be specified (but checked).</li> <li>The settings of tenkey blocks are set in DIV4 as settings for [Data Block Area] mode.                             <ul style="list-style-type: none"> <li>[Data Block Area] mode                                     <ul style="list-style-type: none"> <li>[Division No: 4]</li> <li>[Command: Internal]</li> <li>[Initial Block/Min. Block: (Set the number of [Start].)]</li> <li>[Max. Block: (Set the number of [End].)]</li> <li>[Item Select: (unchecked)] (Set if necessary.)</li> <li>[GD 80 Compatible: (checked)]</li> </ul> </li> </ul> </li> </ul>																			
[Type: Block Direct]	<ul style="list-style-type: none"> <li>[Type: Block]</li> <li>[Target Memory: Direct]</li> <li>[Input Item Select: Internal]</li> <li>[GD 80 Compatible] cannot be specified (but checked).</li> <li>The settings of tenkey blocks are set in DIV4 as settings for [Data Block Area] mode.                             <ul style="list-style-type: none"> <li>[Data Block Area] mode                                     <ul style="list-style-type: none"> <li>[Division No: 4]</li> <li>[Command: Internal (same as GD-80)]</li> <li>* When [Command: External] is set, the address of [Block No. Read Mem.] is the same as of [Command Memory] in [Entry] mode.</li> <li>[Item Select: (checked)]</li> <li>* Specify the same number as [Command Memory] n+1 and choose [2] words.</li> <li>[GD80 Compatible: (checked)]</li> </ul> </li> </ul> </li> </ul>																			
[Type: Multi]	<ul style="list-style-type: none"> <li>[Type], [Target Memory], [Input Item Select] and [GD 80 Compatible] are set same as that in case of [Type: Block Direct].</li> <li>The settings of tenkey blocks are the same as that of [Data Block Area] mode in case of [Type: Block Direct].                             <ul style="list-style-type: none"> <li>* When [Command: External] is set, the address of [Block No. Read Mem.] is the same as of [Command Memory] in [Entry] mode. When the overlap containing the keypad is stored in another screen (= multi-overlap is used), [Block No. Read Mem.] is temporarily set in [\$u4000]. Be sure to change it from [\$u4000] to the address of [Command Memory].</li> </ul> </li> </ul>																			

Item \ Model	GD-80	V6															
Character Entry mode	—	<ul style="list-style-type: none"> <li>Entry mode</li> <li>[Type: Data Display]</li> <li>[Command Memory: (same as [Memory] in GD-80)]</li> <li>[Info. Output Memory: (converted to Write Area n+2)]</li> <li>[Target Memory: Direct]</li> <li>[Input Item Select: Internal]</li> <li>[Detail] tab window <ul style="list-style-type: none"> <li>[Use Graphic: (checked)]</li> </ul>           (Both [Start Graphic] and [End Graphic] are automatically set same as [Initial Graphic No.] of [Character Entry] mode in GD-80. If necessary, specify [End Graphic] later.)</li> <li>For character displays on a screen, [Display Function: Entry Target] is set.</li> </ul>															
Statistics graph mode	—	<ul style="list-style-type: none"> <li>The DIV No is converted as follows.</li> </ul> <table border="1"> <tr> <td>DIV No.</td> <td>0</td> <td>1</td> <td>2</td> <td>3</td> </tr> <tr> <td>Graph No.</td> <td>0 1 2 3</td> <td>0 1 2 3</td> <td>0 1 2 3</td> <td>0 1 2 3</td> </tr> <tr> <td>V6 DIV No.</td> <td>0 10 11 12</td> <td>1 20 21 22</td> <td>2 30 31 32</td> <td>3 40 41 42</td> </tr> </table> <ul style="list-style-type: none"> <li>For [Result Display: checked], the numerical display [Display Function: No] is set in the same DIV No. as that of a statistics graph. [Memory] of each numerical display is the same as [Memory] of the graph.</li> <li>For [% Display: checked], the numerical display [Display Function: Display Statistics Graph %] is set in the same DIV No. as that of a statistics graph.</li> </ul>	DIV No.	0	1	2	3	Graph No.	0 1 2 3	0 1 2 3	0 1 2 3	0 1 2 3	V6 DIV No.	0 10 11 12	1 20 21 22	2 30 31 32	3 40 41 42
DIV No.	0	1	2	3													
Graph No.	0 1 2 3	0 1 2 3	0 1 2 3	0 1 2 3													
V6 DIV No.	0 10 11 12	1 20 21 22	2 30 31 32	3 40 41 42													

### Incompatible Functions after Conversion

There are functions for which compatibility with GD-80 cannot be maintained after converting to V6.

The following describes these functions

Item \ Model	GD-80	V6
General-purpose serial communication	General-purpose serial communication protocol, special to GD-80, is used.	Impossible Since the general-purpose communication protocol, special to V series, is used, the protocol is not compatible.
Communication parameter	Baud rate 1200 and 2400 bps are available.	Impossible Both baud rates are automatically converted to 4800 bps.
Display characters	Characters to be displayed are not influenced by Enlarge X/Y setting.	When an even value is set for Enlarge X/Y, such characters are automatically displayed in 32-dot font. Accordingly, displayed image will somewhat differs from the characters displayed at GD-80. (When [Japanese 32] selected in [Font Setting] of [System Setting] as font is changed to [Japanese], displayed image will come close to the characters displayed at GD-80.)
Overlap [Type: Multi]	Memory n : Indicates the screen No. where the displayed overlap is registered.  When the overlap is cleared, the screen No. entered last remains in memory n.	Memory n : The number in the [multi-overlap] in which the displayed overlap is registered.  When the overlap is cleared -1 (= HFFFF) is set in memory n.
Character-string of switch/memory	Character-strings are created in graphics.	Character-strings are converted as graphics. They are not converted as character-strings in the [Switch] (or [Lamp]) dialog.

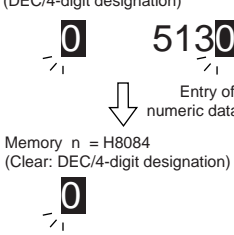
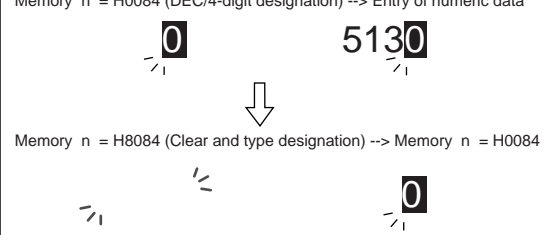
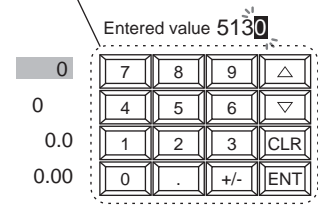
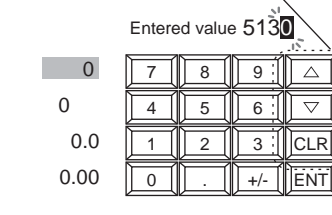

Item \ Model	GD-80	V6
<p>Numeric key mode [Type: Direct Command]</p>	<p>Memory n : Clear (bit 15) The write flag and displayed value of numeric data entry are cleared at the timing this bit is turned ON (0 --&gt; 1).</p> <p>Memory n = H0084 (DEC/4-digit designation)</p>  <p>Memory n = H0804 (Clear: DEC/4-digit designation)</p>	<p>Input mode [Command Memory]: n Clear (bit 15) When this bit is turned ON, the write flag is cleared, and the display of entered data itself is also cleared. Entry is enabled when data type and the digit number, etc. are designated after turning OFF the clear bit (bit 15).</p> <p>Memory n = H0084 (DEC/4-digit designation) --&gt; Entry of numeric data</p>  <p>Memory n = H0804 (Clear and type designation) --&gt; Memory n = H0084</p>
<p>Numeric key mode [Type: Block Entry]</p>	<p>Memory n : Clear (bit 15) After the entry of numeric data using the numeric keypad, the keys are completely disabled. At the leading edge (0 --&gt; 1) of bit 15, the write flag using the numeric keypad is cleared and the keypad disabled state is canceled.</p> <p>All switches are disabled. (until the clear bit is set ON.)</p> 	<p>Input mode [Command Memory]: n Clear (bit 15) After the entry of numeric data using the numeric keypad, entry for the same data item is not allowed. However, since the clear (CL) key is valid, the numeric keypad is enabled by pressing the clear key. In addition, since the [UP] and [DW] keys are always valid, entry using the numeric keypad is accepted after moving the cursor to the next data entry objective data item. To enter the data for the same data item continuously, this bit is valid.</p> <p>Only these keys are valid.</p> 
<p>Trend graph</p>	<p>Control Memory Memory n specified by each [0 to 15 tab windows] ( n exists by the number of display counts)</p> <p>Graph value memory Memory n (specified by each [0 to 15 tab windows]) + 1</p>	<p>Control Memory Only memory n specified by No. 0 of graph at GD-80 (All graph broken lines are controlled by memory n ) <b>* It is not possible to gain the totally identical control as GD-80.</b></p> <p>Graph value memory Memory n (specified by each [0 to 15 tab windows]) + 1</p>
<p>Sampling (Bit / Data / Trend)</p>	<p>During scrolling in the sampling data area using the [Roll Up]/[Roll Down] /[Plus Block]/[Minus Block] switch, nothing is displayed in the display area.</p>	<p>During scrolling in the sampling data area using the [Roll Up]/[Roll Down]/[Plus Block]/[Minus Block] switch, the cursor is displayed and the data currently selected can be recognized.</p>

Item	Model	GD-80	V6
Sampling (Trend)		Count value is displayed only at V6.  Count of the zero position is displayed at the lower left area of the graph.	Numeric values [Display Function: Sample Count Display], [Digits: 3] and [Char. Type: 1/4] are set at the lower left area of the graph.  The current count is displayed.
Sampling (bit)		A space of 1-byte character size is provided between the display in the area and the message.	A space of four 1-byte character size is provided between the display in the area and the message.
Memory card mode		Card No. /Card name /File name /Record name edit Edited and entered No./name are once stored in the PLC memory.  Switch [Action] • [File Select] • [Record Select] • [Selection Complete]  To select a file/record in the card, follow either of the procedures below. [File Select] -> (1) [Selection Complete] -> (2) [Selection Complete], or [Record Select] -> [Selection Complete]	Card No. /Card name /File name /Record name edit Impossible Since No./name is directly written in the memory card, nothing is stored in the PLC memory.  Switch [Function] -> [File Select] -> [Record Select] -> (None)  To select a file/record in the card, follow either of the procedures below. [File Select] -> (1)(2) (Press the display area) [File Select] -> [Record Select] -> (Press the display area)  The operation press the display area is used instead of pressing the [Selection Complete] at GD-80.
		Switch [Action] • [File Name Edit] • [Record Name Edit]  Press [File Name Edit] or [Record Name Edit] after selecting a file or a record, and the multi-overlap for which the character entry mode is set is displayed.	Switch [Function] -> [File Name Edit] -> [Record Name Edit]  Select a file or a record after turning ON the [File Name Edit] or [Record Name Edit] switch, and the multi-overlap for which the entry mode is set is displayed.

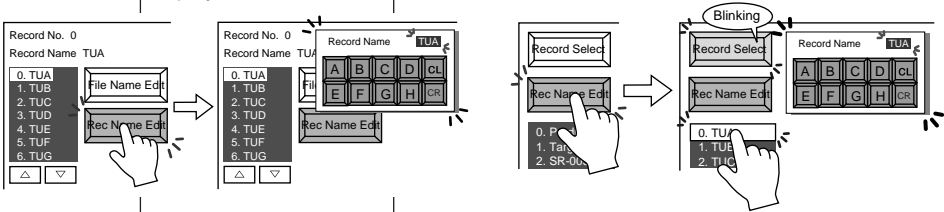
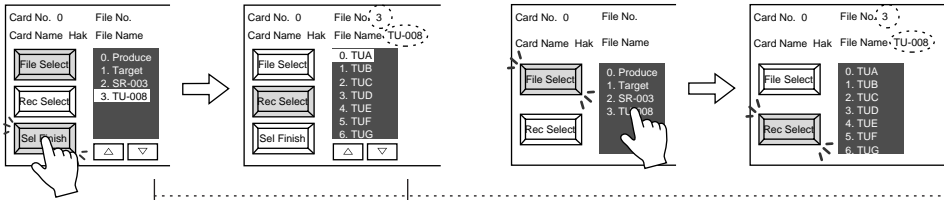

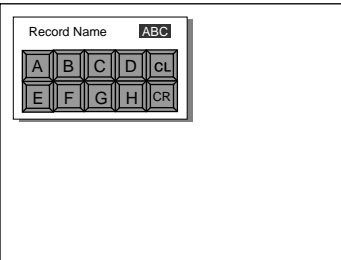
Item \ Model	GD-80	V6
<p>Editing No./name in the memory card mode</p>	<ul style="list-style-type: none"> <li>Multi-overlap is always used.</li> <li>Editing is impossible unless [Memory] bit 12 of the numeric keypad entry mode/character entry mode for No./ editing is set ON.</li> <li>An overlap is deleted when the [ENT] key is pressed and the card No. or the card name /file name/record name is entered</li> </ul> <p>Screen No. 20 (GD-80)</p>  <p>For the screen on GD-80, where nothing is registered other than the normal overlap.</p>	<p>In the state after conversion, converted data cannot be used as it is.</p> <p>Take the following into consideration.</p> <ol style="list-style-type: none"> <li>1) In the state the normal overlap for [Type: Multi] is registered in the screen, the overlap is transferred to the same area of the screen No. of [multi-overlap edit].</li> <li>2) The entry mode on the overlap is always changed to [Type: Memory Card].</li> <li>3) [Num. Display] parts or [Char. Display] parts of [Display Function: Entry display] are always set in the same DIV as the entry mode on the overlap.</li> <li>4) If [Data Block Area] is set on the overlap, it is deleted since it is unnecessary.</li> <li>5) Name display parts are automatically converted in [Bytes: 3]. Therefore, setting should be changed if necessary.</li> </ol> <p>The memory card mode operates normally by the setting indicated above.</p> <p>* [Command Memory] operation in the [Entry] mode is not necessary.</p>
Line	Among the eight kinds of lines, four kinds of lines can be edited as needed.	Impossible Six line kinds are provided in total and all of them are fixed.

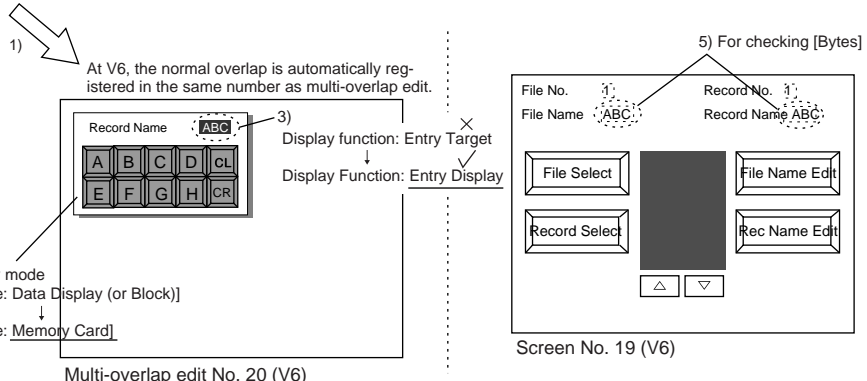

# MEMO

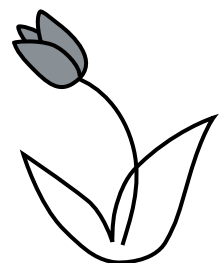

Please use this page freely.



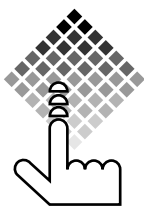

**MONITOUCH**

 **Hakko Electronics Co., Ltd.**

---

Sales

890-1, Kamikashiwano-machi, Matto-shi, Ishikawa, 924-0035 Japan  
TEL: +81-76-274-2144 FAX: +81-76-274-5208